

TA-AV650/AV650G

SERVICE MANUAL

US Model
TA-AV650

E Model
TA-AV650G

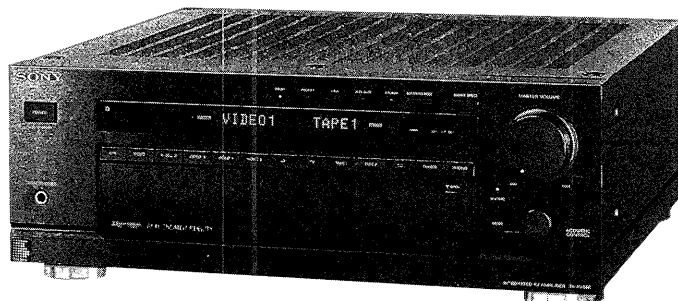

Photo : TA-AV650

TABLE OF CONTENTS

<u>Section</u>	<u>Title</u>	<u>Page</u>
1.	SERVICING NOTE.....	2
2.	GENERAL	3
3.	BLOCK DIAGRAM	
3-1.	Block Diagram	15
3-2.	Explanation of IC Terminals	21
4.	ELECTRICAL ADJUSTMENTS	24
5.	DIAGRAMS	
5-1.	IC Block Diagrams	26
5-2.	Circuit Boards Location	28
5-3.	Printed Wiring Boards -Audio Section-	30
5-4.	Schematic Diagram -Audio Section-	33
5-5.	Schematic Diagram -AMP Section-	38
5-6.	Printed Wiring Boards -AMP Section-	43
6.	EXPLODED VIEWS	
6-1.	Front Panel and Cabinet Section	49
6-2.	Chassis Section	50
7.	ELECTRICAL PARTS LIST	51

INTEGRATED STEREO AV AMPLIFIER
SONY®



SECTION 1

SERVICING NOTE



Adjusting the Operating Voltage(E Model)

- When using in an area where the voltage is 240V, When using a set designated for the E region (220V specifications) in an area where the voltage is 240V, reconnect the connector connected to CNV903 to CNV904.

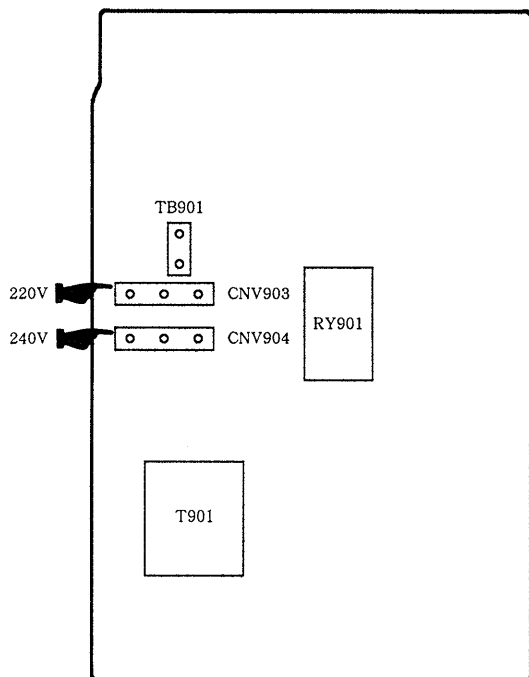
[AC BOARD] COMPONENT SIDE



SAFETY-RELATED COMPONENT WARNING!!

COMPONENTS IDENTIFIED BY MARK  OR DOTTED LINE WITH MARK  ON THE SCHEMATIC DIAGRAMS AND IN THE PARTS LIST ARE CRITICAL TO SAFE OPERATION. REPLACE THESE COMPONENTS WITH SONY PARTS WHOSE PART NUMBERS APPEAR AS SHOWN IN THIS MANUAL OR IN SUPPLEMENTS PUBLISHED BY SONY.

SAFETY CHECK-OUT (US Model)

After correcting the original service problem, perform the following safety check before releasing the set to the customer:

Check the antenna terminals, metal trim, "metallized" knobs, screws, and all other exposed metal parts for AC leakage. Check leakage as described below.

LEAKAGE TEST

The AC leakage from any exposed metal part to earth ground and from all exposed metal parts to any exposed metal part having a return to chassis, must not exceed 0.5 mA (500 microamperes). Leakage current can be measured by any one of three methods.

1. A commercial leakage tester, such as the Simpson 229 or RCA WT-540A. Follow the manufacturers' instructions to use these instruments.
2. A battery-operated AC milliammeter. The Data Precision 245 digital multimeter is suitable for this job.
3. Measuring the voltage drop across a resistor by means of a VOM or battery-operated AC voltmeter. The "limit" indication is 0.75 V, so analog meters must have an accurate low-voltage scale. The Simpson 250 and Sanwa SH-63Trd are examples of a passive VOM that is suitable. Nearly all battery operated digital multimeters that have a 2V AC range are suitable. (See Fig. A)

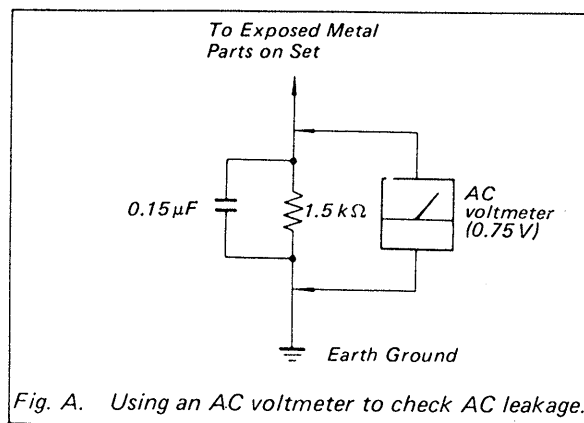

Fig. A. Using an AC voltmeter to check AC leakage.

SECTION 2
GENERAL

This section is extracted from instruction manual.

Specifications (Models for Other Countries)

Amplifier section
Power output (6 ohms, at 1 kHz)
Front: 120 W + 120 W
Center: 120 W
Rear: 40 W + 40 W
Continuous RMS power output
Front: 70 W + 70 W (6 ohms, 20 Hz-20 kHz, THD 0.03%)
Less than 0.03%
Harmonic distortion at rated output
Less than 0.03%
Intermodulation (IM) distortion at rated output
Less than 0.03%Frequency response
PHONO: RIAA equalization curve ±0.5 dB
TUNER, CD TAPE 1, 2, VIDEO 1 - 5, LD, TV: 10 Hz - 100 kHz -3dB
Residual noise
SIN
TUNER, CD TAPE 1, 2, VIDEO 1 - 5, LD, TV: 92 dB(A)

Output	Output jack	Output level	Impedance
TAPE 1, 2, VIDEO 1, 2, 3, MONO	1 V	150 mV	470 kohms
CENTER	6 V	3 mW/8 ohms	1 kohm
HEADPHONES	3 mW/8 ohms	Accepts low and high impedance headphones.	

Equalizer
FRONT: BASS (100 Hz) ±10 dB
TREBLE (10 kHz) ±10 dB
CENTER: BASS (100 Hz) ±10 dB
TREBLE (10 kHz) ±10 dB
MID (1 kHz) ±6 dB
REAR: BASS (100 Hz) ±10 dB
TREBLE (10 kHz) ±10 dB
E.R. Time (HALL, STADIUM): 0 to 90 ms at interval of 3 ms
E.R. Time (THEATER, JAZZ CLUB): 0 to 51 ms at interval of 3 ms
Effect Level: 0 to 100% (11 steps)
Delay Time: 15 ms to 30 ms at interval of 3 ms
Rear Level: 0 to -60 dB →∞ at interval of 1 dB
Center Level: 0 to -60 dB →∞ at interval of 1 dB
Input balance: Automatically adjusted

General
Power requirements 120 V AC, 60 Hz
Power consumption 250 W
AC outlets 2 switched, total 300 W
1 unswitched, 300 W max.
Dimensions 470 x 165 x 430 mm (wh/d) (18 1/2 x 6 1/2 x 17 inches)
Weight 17 kg (37 lb 7 oz)
Supplied accessories Remote commander RM-P650 (1)
Sony Batteries SUM-3 (NS) (2)
Screws (8)
Design and specifications subject to change without notice.

Specifications (U.S.A. model)

POWER OUTPUT AND TOTAL HARMONIC DISTORTION
With 8-ohm load, both channels driven, from 20 ~ 20,000 Hz, rated 70 watts per channel minimum RMS power, with no more than 0.03% total harmonic distortion from 250 milliwatts to rated output.

Amplifier section
Continuous RMS power output (8 ohms)
Center: 70 W
Rear: 30 W + 30 W
Dynamic power output
Front: 120 W + 120 W (8 ohms, at 1 kHz IHF)
Less than 0.03%
Harmonic distortion at rated output
Less than 0.03%
Intermodulation (IM) distortion at rated output
Less than 0.03%
Frequency response
PHONO: RIAA equalization curve ±0.5 dB
TUNER, CD TAPE 1, 2, VIDEO 1 - 5, LD, TV: 10 Hz - 100 kHz -3dB
Residual noise
Damping factor 50 (8 ohms, at 1 kHz)
SIN
TUNER, CD TAPE 1, 2, VIDEO 1 - 5, LD, TV: 92 dB(A)

Video section

Input	Input jack	Sensitivity	Impedance
VIDEO	VIDEO 1, 2, 3, 4, 5, LD, TV	1 Vp-p	75 ohms
S-VIDEO	VIDEO 1, 2, 4, 5, LD	Luminance (Y): 1 Vp-p/75 ohms Chroma (C): 0.285 Vp-p/75 ohms	

Output

Output jack	Sensitivity	Impedance
VIDEO 1, 2, 3, MONITOR	1 Vp-p	75 ohms
S-VIDEO 1, 2, MONITOR	Luminance (Y): 1 Vp-p/75 ohms Chroma (C): 0.285 Vp-p/75 ohms	

Audio section

Input	Input jack	Sensitivity	Impedance
PHONO		2 mV	50 kohms
TUNER, TAPE 1, 2, VIDEO 1, 2, 3, 4, 5, LD, TV, CD		150 mV	50 kohms

Equalizer
FRONT: BASS (100 Hz) ±10 dB
TREBLE (10 kHz) ±10 dB
CENTER: BASS (100 Hz) ±10 dB
MID (1 kHz) ±6 dB
REAR: BASS (100 Hz) ±10 dB
TREBLE (10 kHz) ±10 dB
E.R. Time (HALL, STADIUM): 0 to 90 ms at interval of 3 ms
E.R. Time (THEATER, JAZZ CLUB): 0 to 51 ms at interval of 3 ms
Effect Level: 0 to 100% (11 steps)
Delay Time: 15 ms to 30 ms at interval of 3 ms
Rear Level: 0 to -60 dB →∞ at interval of 1 dB
Center Level: 0 to -60 dB →∞ at interval of 1 dB
Input balance: Automatically adjusted

General
Power requirements 220 V AC, 50/60 Hz
Power consumption 260 W
AC outlets 2 switched, total 300 W
1 unswitched, 300 W max.
Dimensions 470 x 165 x 430 mm (wh/d)
Weight 16.4 kg
Supplied accessories Remote commander RM-P650 (1)
Sony Batteries SUM-3 (NS) (2)
Screws (8)

Video section

Input	Input jack	Sensitivity	Impedance
VIDEO	VIDEO 1, 2, 3, 4, 5, LD, TV	1 Vp-p	75 ohms
S-VIDEO	VIDEO 1, 2, 4, 5, LD	Luminance (Y): 1 Vp-p/75 ohms Chroma (C): 0.285 Vp-p/75 ohms	

Output

Output jack	Sensitivity	Impedance
VIDEO 1, 2, 3, MONITOR	1 Vp-p	75 ohms
S-VIDEO 1, 2, MONITOR	Luminance (Y): 1 Vp-p/75 ohms Chroma (C): 0.285 Vp-p/75 ohms	

Audio section

Input	Input jack	Sensitivity	Impedance
PHONO		2 mV	50 kohms
TUNER, TAPE 1, 2, VIDEO 1, 2, 3, 4, 5, LD, TV, CD		150 mV	50 kohms

Output

Output jack	Output level	Impedance
TAPE 1, 2, VIDEO 1, 2, 3, MONO	150 mV	470 kohms
CENTER	1 V	—
HEADPHONES	6 V	1 kohm
	3 mW/8 ohms	Accepts low and high impedance headphones.

Design and specifications subject to change without notice.

Block Diagram

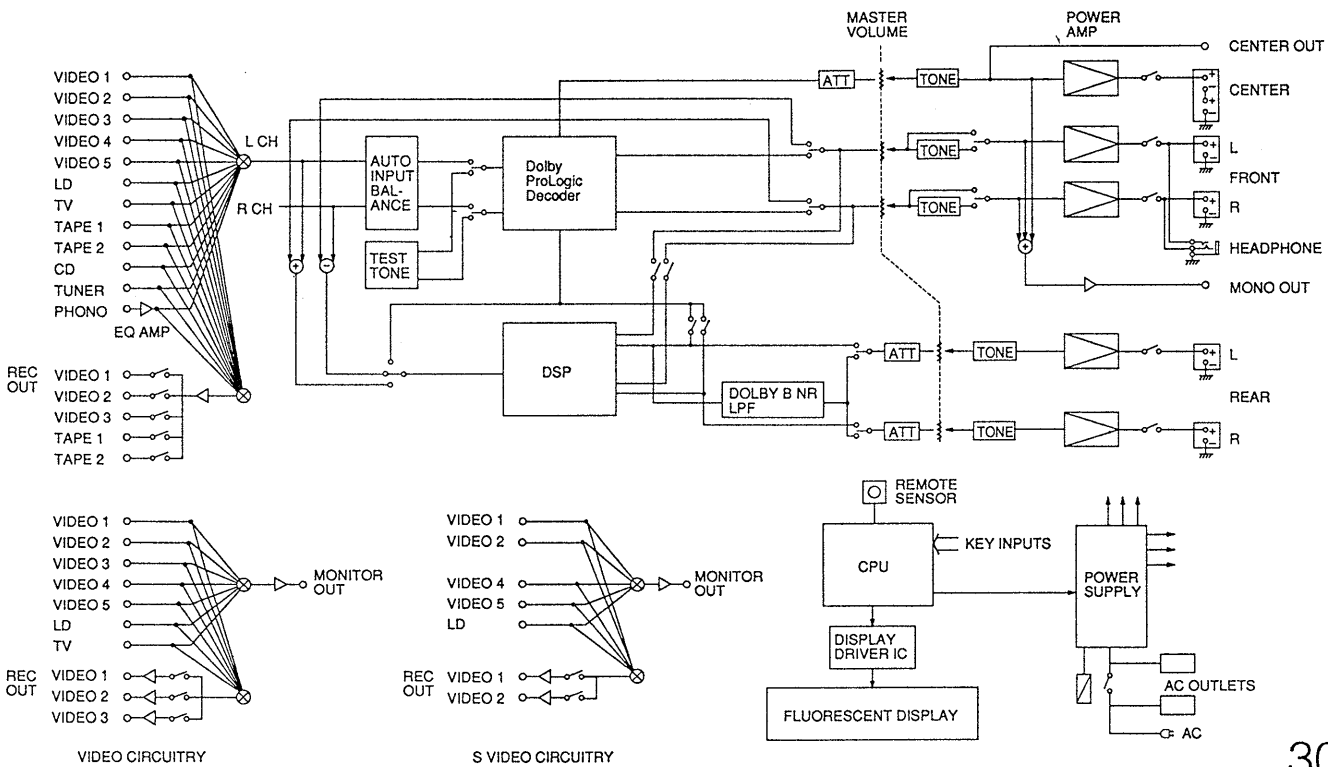

30

Outline

The TA-AV650/TA-AV650G is an AV amplifier with 5 power amplifiers. You can enjoy various audio and video program sources with this unit.

5 high power amplifiers

To enjoy surround sound system easily, the unit incorporates two 120-W (70-W for U.S.A. model) amplifiers for front speakers, one 120-W (70-W for U.S.A. model) amplifier for center speaker(s), and two 40-W (30-W for U.S.A. model) amplifiers for rear speakers.

Spontaneous twin drive power circuit

Condensers having large capacity are used for the voltage complication drive stage of class A and power output stage of class B. Thus, a stable output and high quality sound are obtained, resulting in exclusion of power interferences. The class A stage realizes a stable operation free from interference of the power stage even when an instantaneous or strong output is received.

Super legato linear system

The power amplifier drives low impedance speakers and assures powerful reproduction without low crossover distortion and switching distortion over the wide range.

Gibraltar chassis

A hard chassis named "Gibraltar" which provides high rigidity and periodic damping characteristics, is employed to reduce distortion caused by vibrations. This reduces air vibrations caused by floor and speakers and also reduces vibrations caused by the power transformer and power transistors.

Digital surround sound system

The TA-AV650/TA-AV650G incorporates a Digital Surround Processor and a Digital Signal Processor. All of 5 types of surround effect – DOLBY*, THEATER, HALL, JAZZ CLUB, and STADIUM have been preset. (Refer to page 18.)

Video and audio control center

- You can control up to 7 video sources – VTRs, a LD player, and a TV (BS) tuner.
- You can add sounds from various audio program sources to video programs using the "MIX" function. (Refer to page 15.)
- You can label to the input selector as you desire. (Refer to page 16.)

Automatic input balance adjusting system

The TA-AV650/TA-AV650G can automatically adjust the input balance on the DOLBY and THEATER surround mode.

Source direct button

A source direct button is employed to reproduce high fidelity sound. Any source can be reproduced without passing through the circuits of surround sound system, tone control, and balance control.

Tone control system for the surround speakers

You can compensate the tone of the surround sounds from front speakers, center speaker(s), and rear speakers independently.

Programmable system commander RM-P650

The supplied remote commander can "learn" the various functions of other infrared type remote commanders.

Functions of Controls

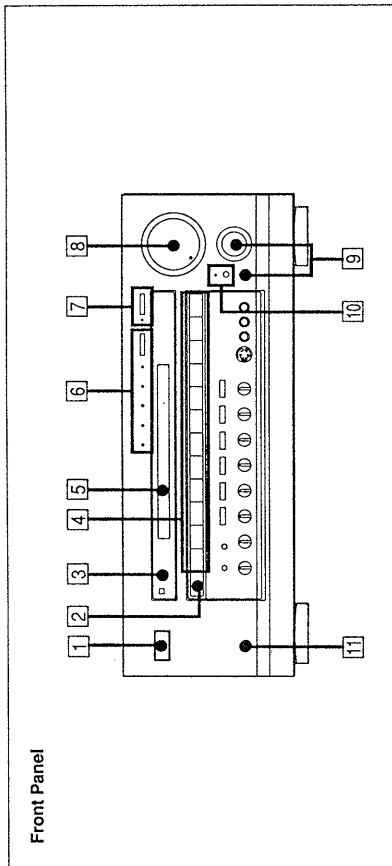

- 1] POWER switch**
Press to turn on the unit. Press again to turn off.
- 2] MIX button**
Press to combine a visual source and an audio source.
(Display: VISUAL source → AUDIO source → off)
- 3] Remote control sensor**
- 4] Input selectors**
Select the program source.
- 5] Display**
- 6] SURROUND MODE selector and indicators**
Selects the surround mode. To set the surround mode to off, press the selector so that no indicator lights up. (Display and indicators: DOLBY → THEATER → HALL → JAZZ CLUB → STADIUM → off)
- 7] SOURCE DIRECT button and indicator**
To enjoy more pure sound, press the button so that the indicator lights up. The sound signal of the program source are directly output to the power amplifier sections without passing through the surround processor, tone control, and balance control.
- 8] MASTER VOLUME control and indicator**
Controls the volume level. To increase the volume level, turn the control clockwise. To decrease the volume level, turn the control counterclockwise.
Note
Turn down the volume before switching on the unit. This prevent damage to speakers.
- 9] HEADPHONES jack**
Accepts the stereo phone plug of headphones. The jack outputs the sound of front speakers only. To listen to the program source only with the headphones, set the FRONT/CENTER and REAR SPEAKERS buttons to OFF (□).
- 10] MUTING button and indicator**
Press the button to mute the sound. Press again to resume the sound.
- 11] MODE button and ACOUSTIC control**
Use these when adjusting volume levels of rear and center speakers, delay time, early reflection, time, and effect level. Press the MODE button to select the parameter, and turn the ACOUSTIC control to adjust the parameter.

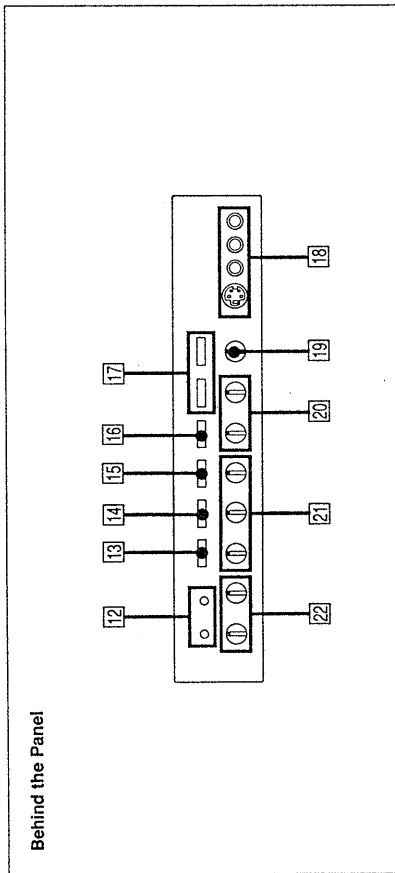

- 12] SPEAKERS buttons**
Normally set these SPEAKERS buttons to ON (■).
FRONT/CENTER: Turns ON (■) and OFF (□) the front and center speakers.
REAR: Turns ON (■) and OFF (□) the rear speakers.
- 13] DISPLAY MODE button**
Press the button to turn on and off the display information. When the display is turned off, to operate the other buttons or controls makes all information to indicate on the display for a few minutes.
- 14] PRO LOGIC MODE button**
Selects the speaker operation mode of DOLBY Pro Logic function.
(Display: NORMAL → WIDE → PHANTOM → 3 CH. LOGIC → CENTER OFF)
- 15] TEST TONE button**
Turns on and off the test tone to adjust the balance among front, rear, and center speakers.
- 16] CHARACTER button**
Labels to input selectors.
- 17] REC OUT buttons**
SET: Sets the desired program source for recording while you listen to/watch another program source.
CHECK: Displays the program source set with the SET button.
- 18] VIDEO 5 input jacks**
Accept S-video, video, and audio input signals.
- 19] BALANCE control**
Adjusts the balance of the right and left front speakers.
- 20] FRONT tone controls**
Control the tone quality of the front speakers.
BASS: Adjusts bass sound.
TREBLE: Adjusts treble sound.
- 21] CENTER tone controls**
Control the tone quality of the center speaker(s).
BASS: Adjusts bass sound.
MID: Adjusts middle sound.
TREBLE: Adjusts treble sound.
- 22] REAR tone controls**
Control the tone quality of the REAR speakers.
BASS: Adjusts bass sound.
TREBLE: Adjusts treble sound.

Functions of Controls

Programmable Remote Commander RM-P650

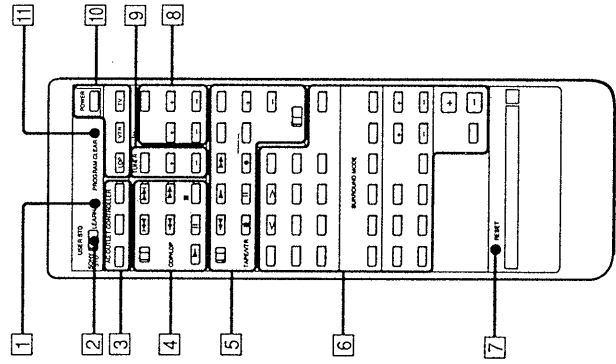

The RM-P650 can "learn" various functions of other remote commanders which use infrared rays. When the mode selector is set to SONY STD (Sony standard), buttons on the RM-P650 can be used to perform the functions below:

- 1 LEARN indicator
Lights up when learning functions.
- 2 MODE selector
SONY STD (standard): To control Sony equipment
USER STD (standard): To control equipment whose remote control functions are stored.
LEARN: To store functions of other remote commanders emitting infrared rays.
- 3 AC OUTLET CONTROLLER buttons
These buttons does not operate with this unit.
- 4 CD player/LD player control section
CD/LDP selector: Selects CD player or LD (Laser Disc) player to be played. The combined CD/LD player can be controlled with this selector set to LDP.
▶: Play
⏸: Pause
■: Stop
◀◀▶▶: AMS (Automatic Music Sensor)
◀◀▶▶: Manual search (only for LD player)
- 5 Tape deck/VTR control section
TAPE/VTR selector: Selects TAPE (tape deck) or VTR to be controlled.
▶: Play
⏸: Pause
■: Stop
◀◀: Rewind
▶▶: Fast forward
●REC: Recording (Press both ●REC button and the right button for recording).

- 6 Amplifier control section
VIDEO 1-5, LD, TV, TAPE 1-2, CD, TUNER, PHONO buttons: Selects program sources.
MIX button: Combines a visual source and an audio source.
SURROUND MODE (ON/OFF, DOLBY, THEATER, HALL, JAZZ CLUB, STADIUM) selectors: Selects the surround mode.
MODE button: Selects the parameter.
ACOUSTIC CONTROL buttons: Adjust the parameter.
PRO LOGIC MODE button: Selects a speaker operation mode on the DOLBY Pro Logic mode.
TEST TONE button: Turns on and off the test tone.
CENTER VOL +/- buttons: Adjust the volume level of the center speaker(s).
REAR VOL +/- buttons: Adjust the volume level of the rear speakers.
DISPLAY MODE button: Turns on and off the display information.
DIMMER button: Selects the brightness on the display.
MASTER VOL +/- buttons: Adjust the level from LINE OUT and HEADPHONES jacks.
MUTING button: Mutes the output signal.
- 7 RESET button
Reset the commander to the initial state.
- 8 TV control section
TV/VIDEO button: Selects the input signal of the TV.
CH +/- buttons: Select a preset channel.
VOL +/- buttons: Control the TV volume.
- 9 Tuner control section
BAND button: Selects the frequency band.
PRESET +/- buttons: Selects a higher or lower preset number.
- 10 POWER buttons
POWER: Turns on and off the TA-AV650/TA-AV650G.
LDP POWER: Turns on and off the LD player.
VTR POWER: Turns on and off the VTR selected by the VTR 1,2,3 selector (usable only when the TAPE/VTR selector is set to VTR).
TV POWER: Turns on and off the TV.
- 11 PROGRAM CLEAR button
Clears the stored functions.

Loading the Batteries

Insert two R6 (size AA) batteries with correct polarity.

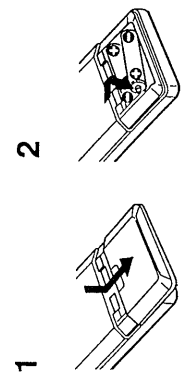

Battery life

About half a year of normal operation can be expected when using the Sony SUM-3 (NS) batteries. When the batteries are exhausted, the commander can no longer operate the unit. Replace both batteries with new ones.

To avoid battery leakage

When the commander is not to be used for a long period of time, remove the batteries to avoid damage caused by battery leakage and corrosion

To avoid malfunction of the remote commander

Avoid keeping the commander under extremely hot or humid locations.

Listening to/Watching Program Sources

Basic Operation

Preparation

- Turn on the connected audio/video equipment.
- Set the SPEAKERS buttons to ON (L).

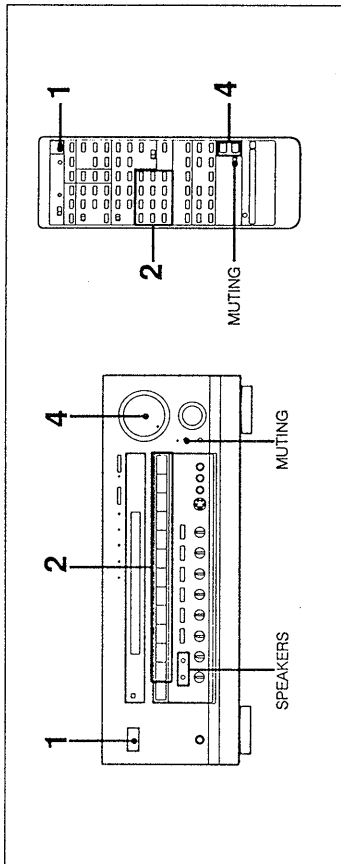

1 Turn on the POWER switch.

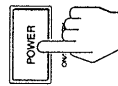

When the MUTING indicator has been lit up
Press the MUTING button to turn it off.

2 Select the program source.

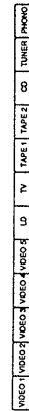

3 Play back the selected program source.

4 Adjust the volume level.

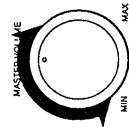

Combining the Video Image with the Sound from Another Program Source

The MIX function allows you to combine a video image with sound from another program source as background music.

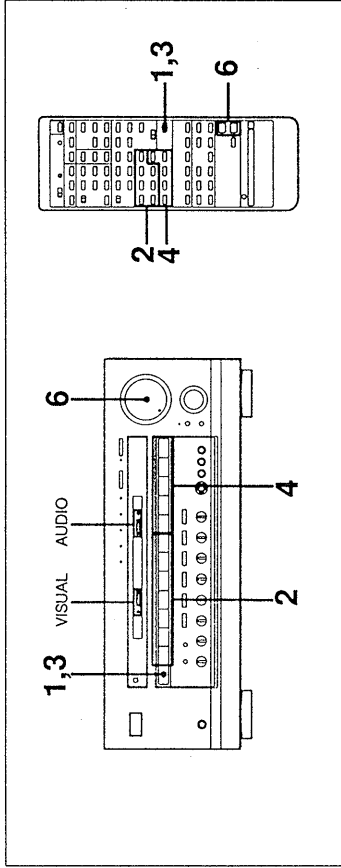

1

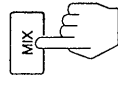

5 Play back both the video and audio program sources.

6 Adjust the volume level.

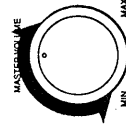

2 Select the video source.



3

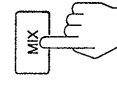

If the MIX button is pressed after both video and audio program sources have been set
The mix function is cancelled and the audio and video signals of the selected video program source is output.

4 Select the audio source. The audio signal of video source can be also selected.

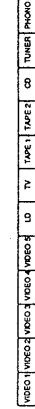

Listening to/Watching Program Sources

Putting Your Own Label on Input Selectors

You can put a label of up to 8 characters on an input selector. The label will appear in the display window when a selector is pressed.

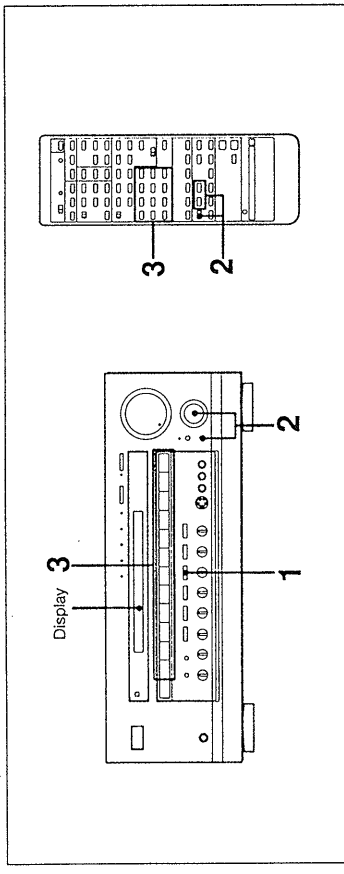

1 To resume the original name of the input selector
Repeat steps 1 to 3 to input the original name.

Usable letters and symbols

Space	!	→	#	←	%	&	'	()	*	+	-	.	/
0	1	2	3	4	5	6	7	8	9	:	<	=	>	?
↑	A	B	C	D	E	F	G	H	I	J	K	L	M	N
↓	P	Q	R	S	T	U	V	W	X	Y	Z	[\]
	~	a	b	c	d	e	f	g	h	i	j	k	l	m
		n	o	p	q	r	s	t	u	v	w	x	y	z

2 Create a name. Three of video selectors may be labeled as VHS, Beta, and 8mm, for example.

To select a letter or number

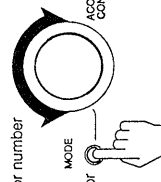

To move the cursor

Now, to resume the last name press the CHARACTER button again.

3 Select an input selector, to be labeled.

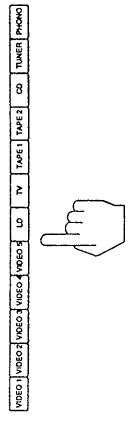

Getting Ready to Enjoy Surround Sound

Positioning the Speakers

Where you place the speakers depends on the size and acoustics of the listening room. The figure below are just examples.

We recommend that you experiment to find the speaker direction or location in which the most effective acoustics can be obtained.

For a basic surround system
Two front and two rear speakers are necessary to enjoy the surround function.

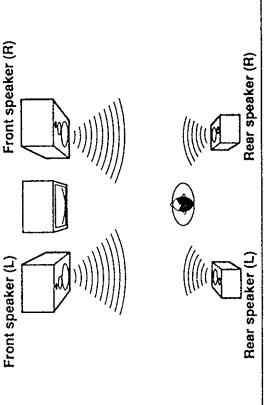

Setting rear speakers
Locate the rear speakers at left and right sides or both rear sides, and at high position to spread the rear surround sound.

For the Dolby Pro Logic surround system (only DOLBY and THEATER modes)
One or two center speakers are required in addition to the basic four speakers.

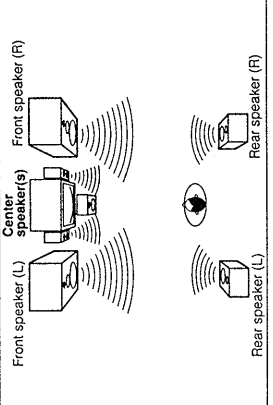

When using two center speakers, set the speakers to both sides of TV. The setting on which the vocal image will be located on the center of the TV screen is better affect to surround effect.

To simulate the Dolby Pro Logic effect without using center speaker
Select the PHANTOM mode in DOLBY Pro Logic modes. The sound of the center channel can be heard from the front speakers.

To obtain rich bass sound
Add a subwoofer to above speaker system.

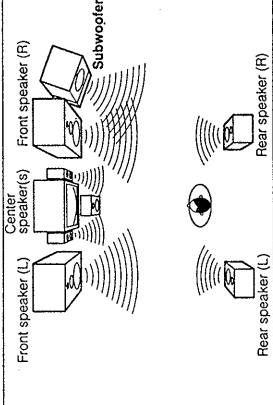

Positioning a subwoofer
Position the subwoofer anywhere forward of your listening position. A deep bass sound is not as directional as the higher frequencies and therefore will not affect the stereo image.

On speaker affinity
To enjoy the surround sound at its best, you should use the same type of speakers for the front, center and rear. If this is not possible, use speakers with the similar efficiency, impedance and sound quality.

Getting Ready to Enjoy Surround Sound

Function of the Surround Sound Modes

The TA-AV650/TA-AV650G incorporates Digital Signal Processor and digital surround processor which contains Dolby Pro Logic Decoder. The digital surround processor electronically reproduces the five kinds of surround soundfield programs which have been preset in the factory as shown below. In the DOLBY and THEATER modes, speaker operation modes can be changed with the Dolby Pro Logic Decoder.

You can enjoy the digital surround sound effects easily by just selecting the surround mode according to the program source.

DOLBY mode (using Pro Logic function)

This mode is for reproducing the movie or sound program source processed with Dolby surround system on which the **DOLBY SURROUND** mark is labeled. You can hear dynamic sound and natural voice just like listening to it in a movie theater or a concert hall.

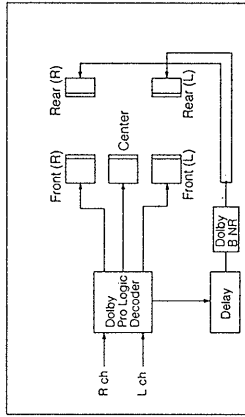

HALL mode

You can hear the naturally acoustic sound having a reverberation effect that is produced in a medium sized concert hall.

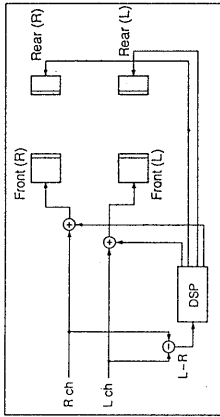

STADIUM mode

This mode is for adding the reverberation effect that is felt in an outdoor stadium to a program source recorded in studio.

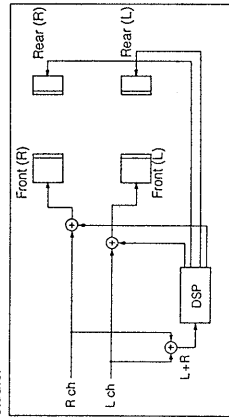

THEATER mode (using Pro Logic function)

This mode is for reproducing the movie program source processed with the Dolby surround system. You can hear a dynamic sound and natural voice just like listening to it in a movie theater. In the mode, reverberation effect is added to the signal processed through the Dolby Pro Logic Decoder.

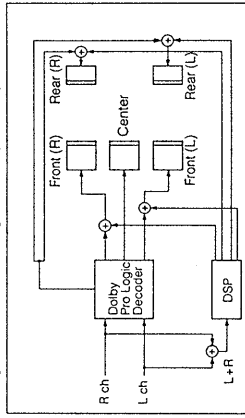

JAZZ CLUB mode

You can hear the powerful and clear sound having an effect that is produced in a jazz club.

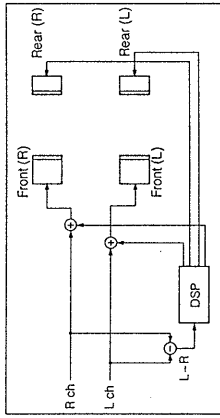

Selecting the Speaker Operation Mode in the Dolby Pro Logic Function (for DOLBY and THEATER Modes)

In the DOLBY and THEATER surround modes, a speaker operation mode can be selected to match your speaker system. Press PRO LOGIC MODE button to select the appropriate mode:

Dolby Pro Logic Mode	Speaker Operating Function
NORMAL	Select this mode if you use small center speaker(s). The bass sound of the center channel is output from the front speakers, as small speaker(s) cannot produce enough bass.
WIDE	Select this mode if you use a medium to big center speaker.
PHANTOM	Select this mode when you do not use center speaker(s). The sound of the center channel can be heard from the front speakers.
3 CH. LOGIC	Select this mode when you do not use rear speakers. The sound of the rear channels can be heard from the front speakers.
CENTER OFF	This mode is only used for checking the input balance in Dolby surround mode. The sound of the center channel, such as voice or vocal, is not heard from the speakers.

NORMAL mode

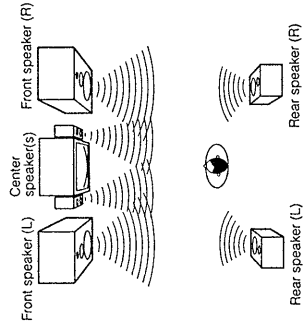

WIDE mode

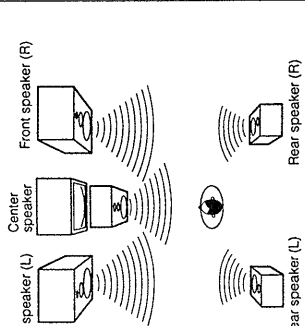

PHANTOM mode

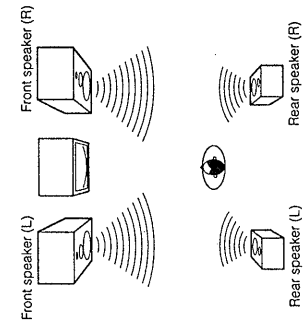

3CH. LOGIC mode

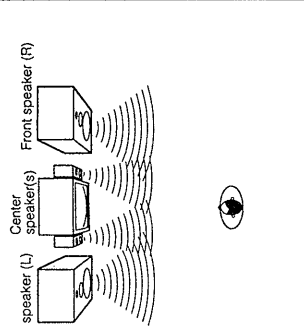

Getting Ready to Enjoy Surround Sound

Adjusting the Volume Level of the Surround Speakers for a System with Center Speaker(s)

To enjoy the surround sound sufficiently, adjust the front, rear and center speakers to the same volume level. The adjustment must be done with a test tone in the Dolby surround mode, but the level once adjusted can be used for all surround modes. You can adjust the volume level from your listening position if you use the remote commander.

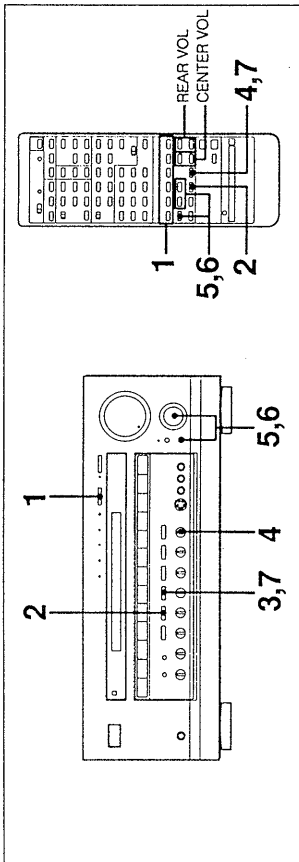

- 1 Select DOLBY mode.
- 2 Select NORMAL or WIDE mode, depending on the size of your center speaker. (See page 19).
- 3 The test tone will be output automatically from the left front [L], center [C], right front [R], and rear speakers [S] in succession.
- 4 Balance the volume level of the left and right front speakers.
- 5 Adjust the volume level of the center speakers so that it will be the same as the front and rear speakers. (It can be adjusted with CENTER VOL buttons on the remote commander.)
- 6 Adjust the volume levels of the left and right rear speakers so that they will be the same as the front speakers respectively. (The volume levels of both channels can be simultaneously adjusted with REAR VOL buttons on the remote commander.)
- 7 Turn off the test tone.

When not using rear speakers
 Press PRO LOGIC MODE button to select 3 CH. LOGIC mode. Press TEST TONE button to output test tone from the left front [L], center [C], right front [R] in succession.

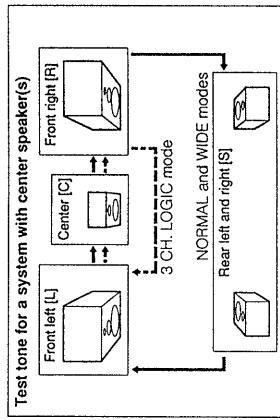

- 5 Adjust the volume level of the center speakers so that it will be the same as the front and rear speakers. (It can be adjusted with CENTER VOL buttons on the remote commander.)

Adjusting the Volume Level of the Surround Speakers for a System without Center Speaker(s)

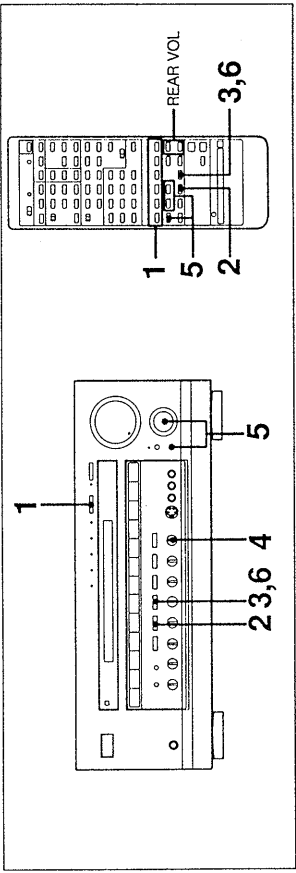

- 1 Select DOLBY mode.
- 2 Select PHANTOM mode.
- 3 The test tone will be output automatically from the front speakers [C] and rear speakers [S] alternately.
- 4 Balance the volume level of the left and right front speakers.
- 5 Adjust the volume levels of the left and right rear speakers so that they will be the same as the front speakers respectively. (The volume levels of both channels can be adjusted with REAR VOL buttons on the remote commander simultaneously.)
- 6 Turn off the test tone.

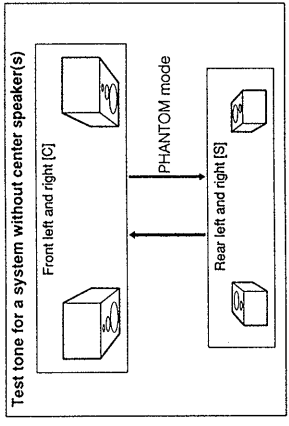

Automatic Input Balance

When playing back a Dolby surround processed video tape or video disc, the input level and input balance must be adjusted to obtain the best surround effect. On the unit, the input balance is automatically adjusted.

Enjoying the Surround Sound

Understanding the Digital Surround System

The sound heard in a place such as a concert hall or a movie theater consists of direct sound, an early reflected sound (early reflections), and a reverberative sound (reverberation). The acoustics of the room affects the way these three sounds are heard. We can estimate the size or the type of a hall by listening to an differentiating these three kinds of sound.

The unit reproduces the early reflections and the

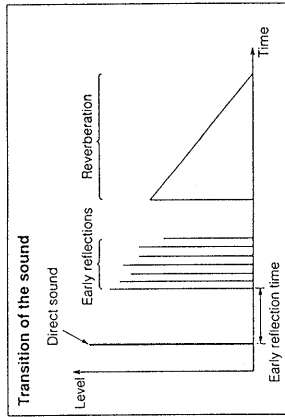
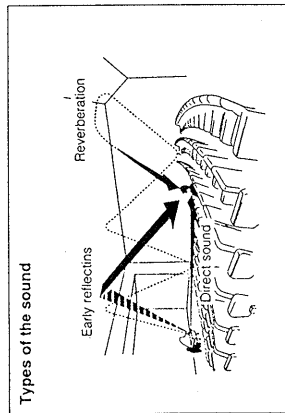

Selecting the Surround Mode

The unit has five surround modes, DOLBY, THEATER, HALL, JAZZ CLUB, and STADIUM modes which have been preset in the factory. Since these programs are appropriate for the most types of music and listening situations, you can

enjoy the digital surround sound effects by just selecting the surround modes according to the program source. You can also adjust several parameters to maximize the effect. (See page 23.)

Adjustable Parameters

The unit reproduces the early reflections and the reverbation using its digital signal processor and allows you to design a variety of soundfields in your own room. The unit incorporates 5 types of surround modes, and within each mode, you can adjust several parameters to maximize the effect in your listening room.

Parameters	Surround Modes	DOLBY	THEATER	HALL	JAZZ CLUB	STADIUM
Rear Level		○	○	○	○	○
Center Level		○ ^{*1}	○ ^{*1}			
Early Relection Time			○ ^{*2}	○	○	○
Delay Time		○ ^{*2}				
Effect Level			○	○	○	○

*1 Center level is not adjusted on the PHANTOM mode in the Dolby Pro Logic modes.

*2 Early reflection time is not adjustable on the 3 CH. LOGIC mode in the Dolby Pro Logic modes.

• Adjusting the delay time is shown on page 24.

• The data of the early reflection time and delay time can be programmed into each surround mode individually. The data of the rear, center, and effect level are same data on all modes.

Adjusting the Tone Quality of Speakers

To enjoy the surround sound sufficiently, adjust the tone of the front, center, and rear speakers respectively to the same quality.

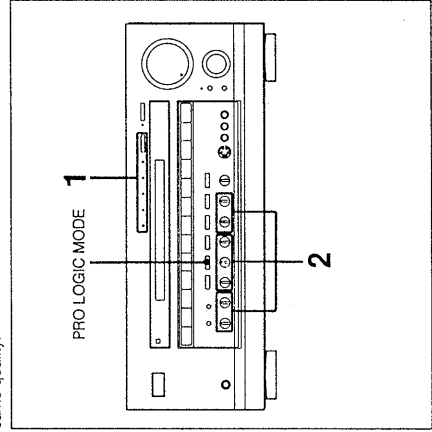

1 Select a surround mode.

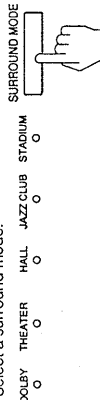

2 Adjust the tone quality of each speakers.



Notes

- You can hear the sound from center speaker(s) only when the DOLBY or THEATER mode is selected.
- The sound from center speaker(s) is not output on the PHANTOM mode in the speaker operation modes.
- The sound from rear speakers is not output on the 3 CH. LOGIC mode in the speaker operation modes.

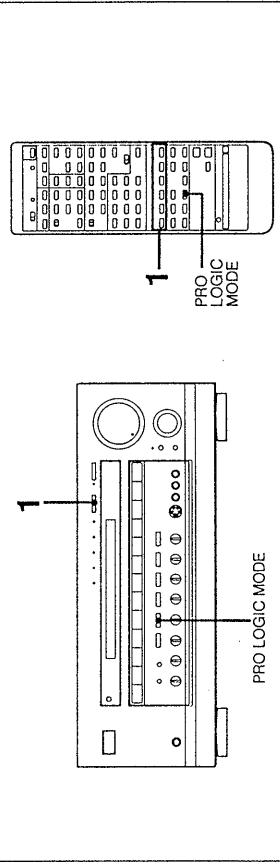

To resume the surround mode

Press the SURROUND MODE selector so that no indicator lights up. On using the remote commander, press the ON/OFF button in SURROUND MODE to turn off the indicator.

When selecting speaker operation modes on the Dolby Pro Logic mode

After selecting the DOLBY or THEATER mode, press the PRO LOGIC MODE button. (See page 19.)

1 Select a surround mode.

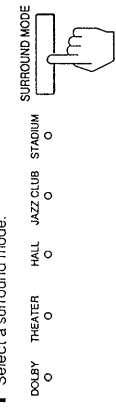

Enjoying the Surround Sound

Adjusting the Delay Time of the Rear Speakers (Only for DOLBY Surround Mode)

The delay time is a time between the surround sound from the front speakers (as direct sound) and that from rear speakers (as reflected sound). The delay time is adjustable from 15 ms to 30 ms. When setting the rear speakers in a large room or apart from your listening position, set the delay time short.

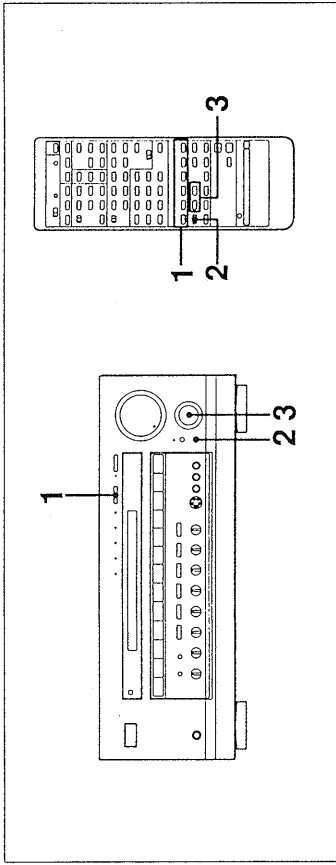

1 Select DOLBY mode.

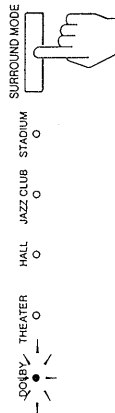

Note
Adjusting the delay time of the rear speakers is available for the Dolby surround processed source.

2 Display the delay time mode.

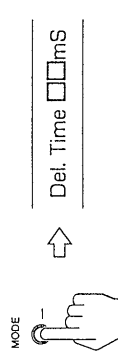

3 Adjust the delay time of the rear speakers.



Adjusting the Early Reflection Time (Except for DOLBY Surround Mode)

The early reflection time is the key parameter which determines the room size and listening position. Adjustment of this parameter will vary the time required for the sound to reach to the listening position. The adjustable range is from 0 ms to 90 ms, and the longer the time, the longer you will feel the distance to the origin of the sound.

When adjusting the parameter
Noise may be output.

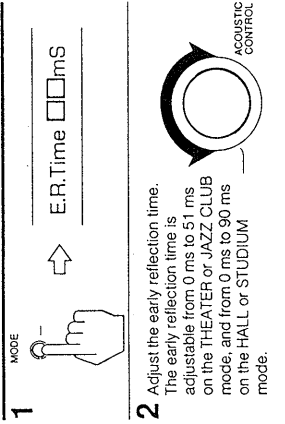
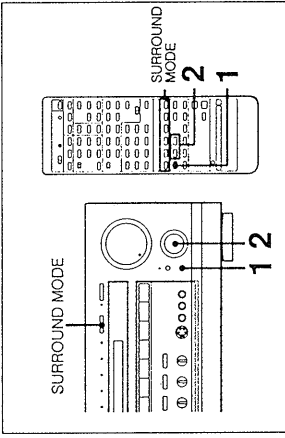
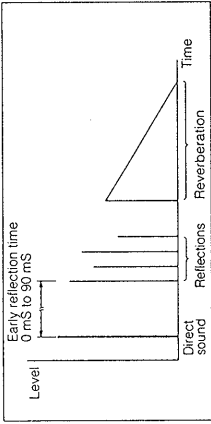

2 Adjust the early reflection time.
The early reflection time is adjustable from 0 ms to 90 ms on the THEATER or JAZZ CLUB mode, and from 0 ms to 90 ms on the HALL or STUDIO mode.

Adjusting the Effect Level (Except for DOLBY Surround Mode)

This parameter adjusts the level of early reflections and reverberation. The adjustable range is from 0 to 10 (100%), and as the number gets larger, the room becomes more "live", and as it gets smaller, the room becomes "dead".

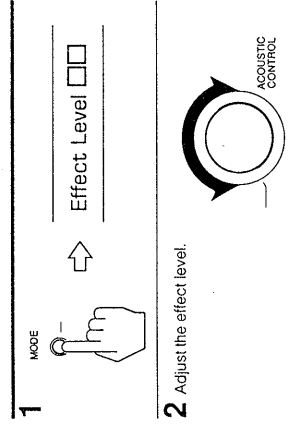
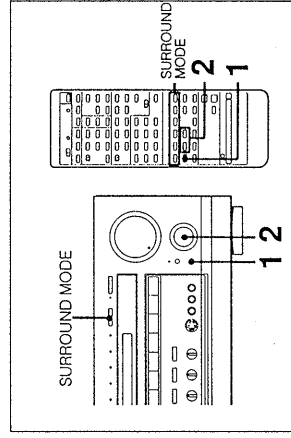
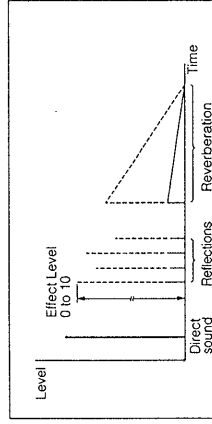

2 Adjust the effect level.

Recording Audio/Video Program Sources

Basic Operation

You can operate two or more video or tape decks for recording at the same time as the audio (and video) signals of the program source is output simultaneously through all recording output jacks.

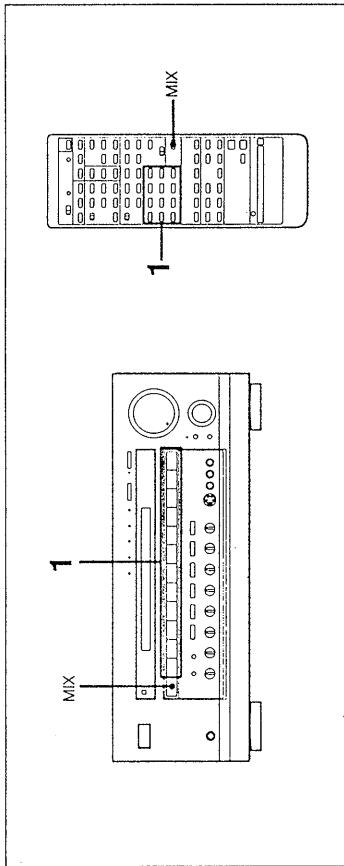

- 1 Select the video or audio program source. If you want to combine video image and the sound from another audio source, press the MIX button to select them independently. (See page 15).

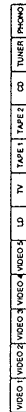

- 2 Set the video or tape deck in the recording mode.

- 3 Play back the selected program source.

Recording Program Sources While Listening to/Watching Another

This unit has separate circuits for line output and or recording, so you can record a program source while listening to/watching another.

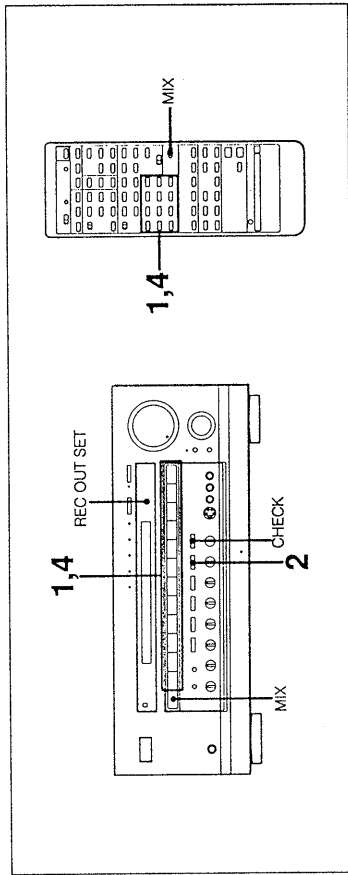

- 1 Select the program source to be recorded. If you want to combine a video image and the sound from another audio source, press the MIX button to select these sources independently. (See page 15).

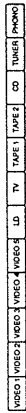

- 2

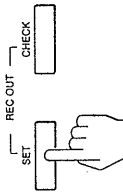

- 3 Play back the selected program source(s) to be recorded and set the video or tape deck into the recording mode.

- 4 After checking that the REC OUT SET is indicated in the display, select the program source to be listened to/watched.



- 5 Play back the selected program source(s).

To check the preset recording outputs

Press and hold the CHECK button to display them in the display window.

To record a listening program source

Press the SET button to go off the REC OUT SET indicator. The program source being listened to/watched is output from the REC OUT jacks.

Monitoring while recording

When a 3-head tape recorder is used, the recorded result can be monitored. When the recording is done on a tape recorder connected to the TAPE 1 or TAPE 2 jacks, the recorded sound can be monitored by selecting TAPE 1 or TAPE 2, respectively.

Using the Remote Commander

- When you manipulate buttons on the commander, be sure to point the head of the commander toward the remote control sensor on the front of the amplifier.
- If there is an obstacle between the amplifier and the head of the commander, the amplifier may not be controlled remotely.

Programming Signals of Other Audio/Video Equipment with RM-P650

The RM-P650 can learn various functions of other remote commanders emitting infrared rays and allows you to control most of audio and video equipment from a distance.

Insert batteries before operation.

You can program signals for each function by switching the CDP/LDP selector.

You can program signals for each function by switching the TAPE/VTR and VTR(1,2,3) selectors (DUAL, ANT TV/VTR, and CH +/- buttons cannot be programmed when the TAPE/VTR selector is set to TAPE).

Other manufacturer's remote commander

Approx. 5 cm (2 inches)

LEARN indicator

1,6

3,4

2,4

Programmable Remote Commander RM-P650

If the LEARN indicator flashes or does not go out in steps 2 - 4.
The memory capacity has become full. This occurs when other signals stronger than the remote-control signals have been stored because the signals were programmed in a noisy environment or the remote commanders were placed too far apart from each other.
→ Clear all the signals following the procedure on the right and program again from the beginning under the proper conditions.

Notes on programming

- Remote-control signals of equipment of manufacturers other than Sony can be programmed only when they are compatible with the infrared wireless remote control system. Since the programmable commander can "learn" only the signals output from another remote commander, it cannot control equipment that does not use a remote commander. Also, note that there are some special remote-control signals that cannot be programmed.
- Do not attempt to use the programmable commander with an air conditioner or other household appliances.

To program a new signal onto a previously programmed button

Follow the programming procedure.
The previously programmed signal is cleared and replaced by the new signal.

- To clear all programmed signals**
- Set the mode selector to LEARN.
 - Press and hold any button of the programmable area until the LEARN indicator lights up.
 - Press PROGRAM CLEAR until the LEARN indicator flashes and goes off.

Note

It is not possible to clear the programmed content of just one button.

To program a signal onto the ● REC button in the TAPE or VTR section

It is not possible to operate any equipment with only the REC button. To program a signal under the ● REC button, press and hold the following buttons at the same time in step 2.

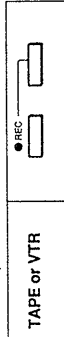

Controlling Equipment

By switching the mode selector as shown below, a single button alternately controls Sony equipment and another manufacturer equipment.

To control Sony equipment

To control equipment with programmed signals

When Sony equipment cannot be remote-controlled
Program the signal in the same way as for equipment from other manufacturers. In this case, even with Sony equipment, set the mode selector to USER STD.

If no signal has been programmed
The programmable commander can control Sony equipment even when the mode selector is set to USER STD.

Notes on Battery

If the LEARN indicator does not light when a button is pressed, the batteries are almost exhausted. When the batteries are exhausted, the remote commander can no longer operate the unit or programming becomes impossible. If this happens, replace both batteries with new ones. We recommend the use of alkaline batteries for prolonged use.

If the equipment works incorrectly

Press RESET.
The programmed contents of the buttons are not cleared by pressing RESET.

- Set the mode selector to LEARN.



- Press and hold the button which shall "learn" the remote-control signal until the LEARN indicator lights up.

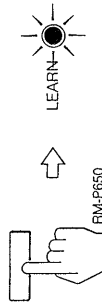

- Press and hold the button of other manufacturer's remote commander whose signal is to be learned.

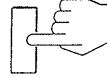

After programming
Be sure to test if the equipment really works with the programmed signals.

Number of signals that the commander can learn
It depends on the format of the signal. If you program signals of Sony equipment, approximately 40 - 50 signals can be programmed.

- Repeat operation for each button to be programmed.

- Set the mode selector to USER STD or SONY STD.

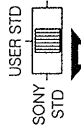

SECTION 3
BLOCK DIAGRAM

3-1. BLOCK DIAGRAM

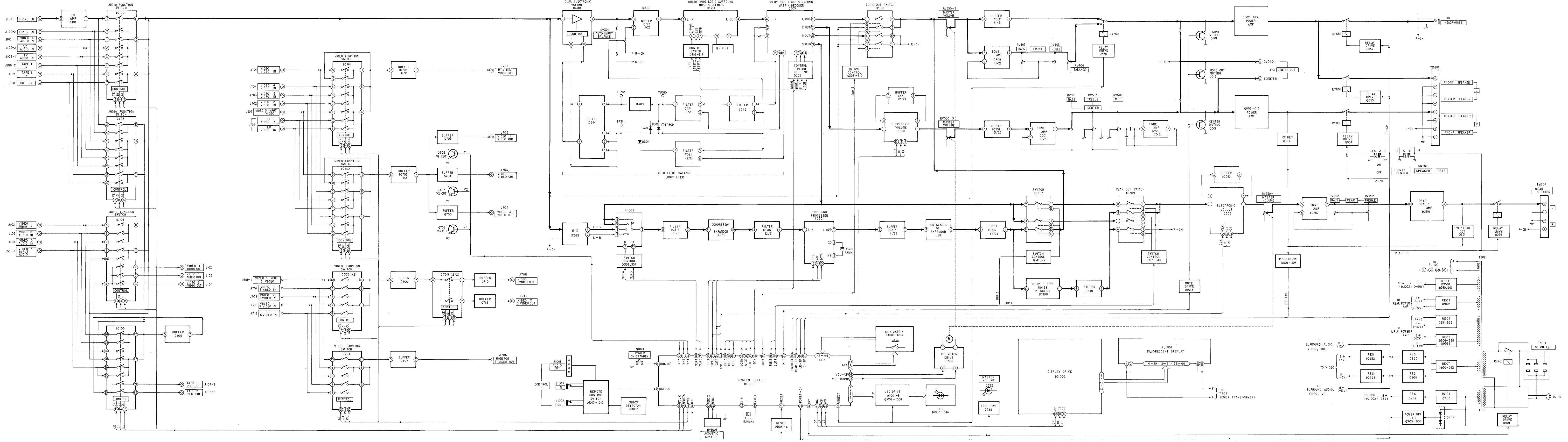

3-2. EXPLANATION OF IC TERMINALS

• IC301 Surround Processor (YM7128)

Pin. No.	Terminal name	I/O	Terminal explanation
1	VDD	—	Digital system +5 V power source
2	AVDD	—	Analog system +5 V power source
3	CH	O	External condenser terminal for sample hold
4	AIN	I	Analog signal input terminal
5	CV	O	Standard voltage output terminal for A/D converter
6	$\overline{\text{TI}}$	I	Test input terminal (always open)
7	LO	O	L-channel output (analog output) terminal
8	RO	O	R-channel output (analog output) terminal
9	AVSS	—	Analog system GND
10	VSS	—	Digital system GND
11	XO	O	Clock output
12	XI	I	Clock input (7.7 MHz)
13	SCI	I	Data shift clock input terminal
14	A0	I	Address/data identification signal input terminal "L" : Address term, "H" : Data term
15	DIN	I	Data input terminal
16	$\overline{\text{IC}}$	I	Initial clear terminal

• IC1002 Display Microcomputer (MSC7128)

Receives display data from the system controller and displays it on the fluorescent tube.

Pin. No.	Terminal name	I/O	Terminal explanation
1~51	COM2~6 SEG1~36	O	Fluorescent tube display drive output
52, 53	+5V	—	Power source terminal (+5 V)
54	RESET	I	Reset input
55	CP	I	Data transmission clock input from system controller (IC1001)
56	DA	I	Serial data input from system controller (IC1001)
57	CS	I	Data latch input from system controller (IC1001)
58	OSC O	O	} CR external terminal for clock oscillator
59	OSC I	I	
60	TEST	—	Not use with this machine. (Always GND)
61	TEST	—	
62	Vss	—	GND
63	VEE	—	Power source terminal of driver circuit (−40 V)
64	COM1	O	Fluorescent tube display drive output

• IC1001 System Controller (M50747)

This controller controls the whole system, such as the control data transmission for DSP, switching the surround mode, data transmission for the display microcomputer (IC1002) to display it on the fluorescent lamp, switching the function switch, VOL control, ON/OFF of LED relay, and key input.

Pin. No.	Terminal name	I/O	Terminal explanation
1	VDD	—	Power source terminal (+5 V)
2	MUT	O	MUTE LED (D1014) output. "H" : light on
3	RECOUT	O	REC OUT LED (D1013) output. "H" : light on
4	DIRECT	O	SOURCE DIRECT LED (D1012), Relay (RY550) output. "H" : light on, Relay ON
5	STADIUM	O	STADIUM LED (D1011) output. "H" : light on
6	JAZZ	O	JAZZ CLUB LED (D1010) output. "H" : light on
7	HALL	O	HALL LED (D1009) output. "H" : light on
8	THEATER	O	THEATER LED (D1008) output. "H" : light on
9	DOLBY	O	DOLBY LED (D1007) output. "H" : light on
10	V3	O	Loop cut control terminal for Video 3 image output. Active : "L"
11	V2	O	Loop cut control terminal for Video 2 image output. Active : "L"
12	V1	O	Loop cut control terminal for Video 1 image output. Active : "L"
13	FCLK	O	Data transmission clock output for audio/video function switch
14	FDATA	O	Serial data output for audio/video function switch
15	FCE	O	Data latch output for audio function switch (IC102~105)
16	VCE	O	Data latch output for video function switch (IC701, 702, 704, and 705)
17	DSPA 0	O	Data latch output for surround processor (IC301)
18	C/R-CE	O	Data latch output for election VOL (IC550 and 555)
19	CLK	O	Data transmission clock output for election VOL (IC550 and 555) and surround processor.
20	DATA	O	Serial data output for election VOL (IC550 and 555) and surround processor.
21	DA	O	Serial data output for display microcomputer (IC1002)
22	CP	O	Data transmission clock output for display microcomputer (IC1002)
23	CS	O	Data latch output for display microcomputer (IC1002)
24	VOL-UP	O	Volume motor (RV550) UP output for IC556 (motor drive)
25	VOL-DOWN	O	Volume motor (RV550) DOWN output for IC556 (motor drive)
26	POWER-ON	I	Power source breakage detection input. Active : \bar{L}
27	Vss	—	Power source terminal (GND)
28	RES	I	Reset input
29	XIN	I	Clock input (8.0 MHz)
30	XOUT	O	Clock output
31	CLK	—	Not used with this machine.
32	Vss	—	Power source terminal (GND)
33	PROTECT	I	Protection detection input of speaker output
34	ON/OFF	I	POWER switch (S1024) input
35	KEY OUT	O	Key matrix output
36			
37			
38			
39			
40			

Pin. No.	Terminal name	I/O	Terminal explanation							
41 42 43 44	KEY IN	I	Key matrix input							
45				NORM	DOLBY SURROUND function mode setting output	NORMAL ④⑤ pin	WIDE ④⑥ pin	CENTER OFF ④⑦ pin	3CH LOGIC ④⑧ pin	Function mode
46				WIDE		L	L	L	L	PHANTOM
47				C-OFF		H	L	L	L	NORMAL
48	3CH	L	H	L		L	WIDE			
		L	H	H		L	CENTER OFF			
		H	L	L	H	3CH LOGIC				
49	TEST3	O	TEST TONE ON/OFF for IC304 (noise sequencer). "L" : TEST TONE ON (only in Dolby surround mode)	TEST1	TEST2	TEST TONE output destination				
50	TEST2	O		H	H	Front L				
51	TEST1	O		TEST TONE direction selector output for IC304 (noise sequencer)	H	L	Center			
					L	H	Front R			
		L	L		Rear LR					
52	SUR5	O	Surround mode setting output. "L" : Dolby, "H" : DSP	SUR3 ④③ pin		SUR4 ④④ pin		Matrix		
53	SUR4	O		L		L		L+R		
54	SUR3	O		Surround mode setting output	L		H		Dolby S OUT	
					H		L		Dolby S OUT	
					H		H		L-R	
55	SUR2									
56	SUR1	O	Surround mode setting output. "L" : Surround, "H" : Source direct		REAR-SP			Rear speaker relay (RV801) control output. At source direct : "L", Normal : "H"		
57		O		LR-SP						
58		O		C-SP						
59		O		Center speaker relay (RY001) control output. At Dolby theater, WIDE • NORMAL : "H"						
				When power is on, the pins ④⑦ to ④⑨ are "L", and when PROTECT turns to "L", they turn to "L", too.						
60	MUT	O	Audio mute output. "L" : Mute							
61	RY	O	Power relay (RY901) control output. "H" : Relay ON (Power ON)							
62	ENC2	I	Rotary encode (RV1001) input					The phase of ENC1 and 2 has slipped 90°.		
63	ENC1									
64	SIRCS	I	SIRCS signal input							

• SUR1~5 (pins ④③ to ④⑤) setting in surround mode

	DOLBY	THEATER	HALL	JAZZCLUB	STUDIUM	SURROUND OFF
SUR1	L	H	H	H	H	don't care
SUR2	L	H	L	L	L	L
SUR3	L	L	H	H	L	don't care
SUR4	H	L	H	H	L	don't care
SUR5	L	L	H	H	H	L

SECTION 4 ELECTRICAL ADJUSTMENTS

- Service mode display with fluorescent lamp

When depressing the **DISPLAY MODE** button while pressing the **TEST TONE** button, the following three patterns are repeatedly displayed :

1. Diced pattern
2. Diced pattern (in reverse of pattern 1)
3. Everything lights

(However, since 10G in the center position is not used and connected, it does not light.)

[Idling adjustment]

Note :

Perform the adjustment procedures after the power switch has been turned ON and having waited for a few minutes.

Adjusting method :

1. Set the master volume to MIN.
2. Connect a tester to the test points of TB001 (Center), TB601 (L-CH) and TB651 (R-CH) and confirm that the reading of the tester become within the following values.
3. If the readings of the tester are bigger than the specified values, solder the taps of R201 (CENTER), R621 (L-CH) and R671 (R-CH).

Specified value : 0.5~10.0mV

Adjusting point : AMP B circuit board

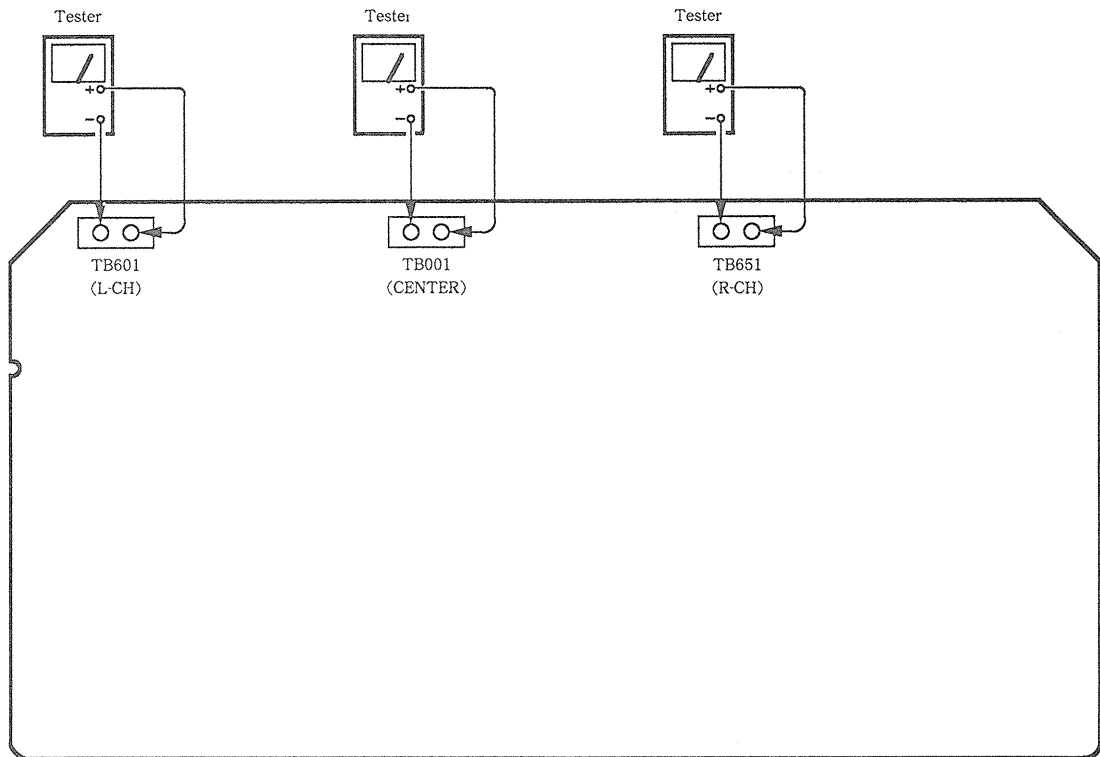

(Part surface side)

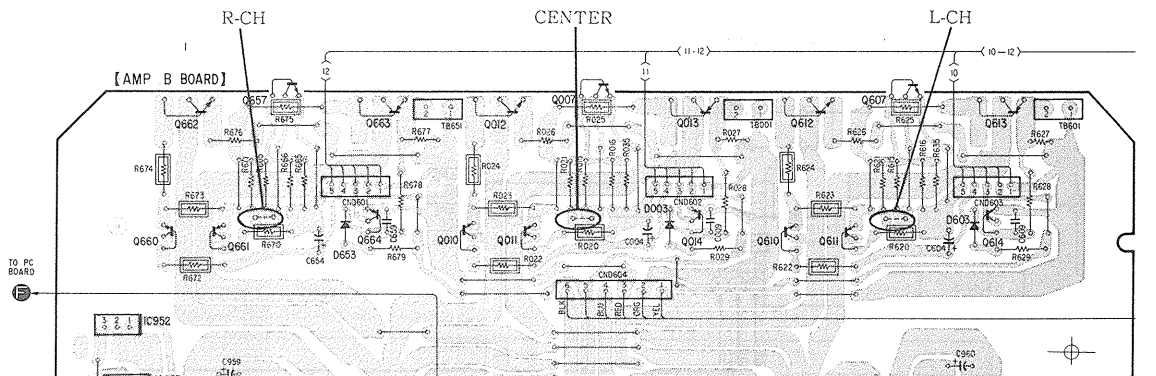

(Pattern surface side)

[AUTO INPUT BALANCE adjustment]

Condition :

PRO LOGIC MODE : CENTER OFF

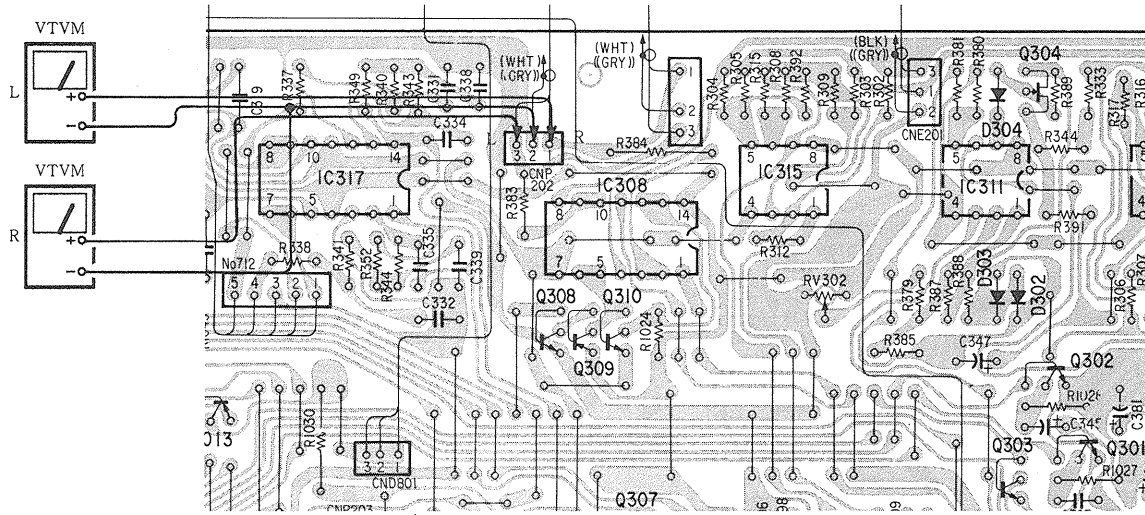

SUR board (Pattern surface)

Adjusting method :

1. Set the function to CD and apply $f=1\text{kHz}$ and approximately 200 mV to both the L and R inputs from the CD input on the back panel.
2. Short circuit C347. (AUTO INPUT BALANCE LOOP CUT)
3. Adjust RV301 so that the VTVM readings of L and R become minimum.
4. Adjust RV302 so that the reading of the tester becomes $0 \pm 5\text{mV}$.
5. Short circuit C347 and confirm that the indications of each meter does not change.

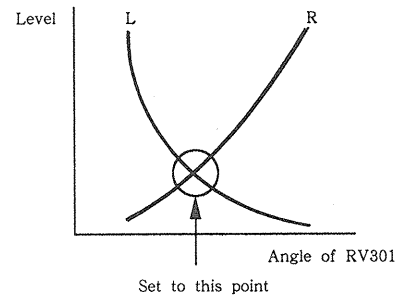

Adjusting point :

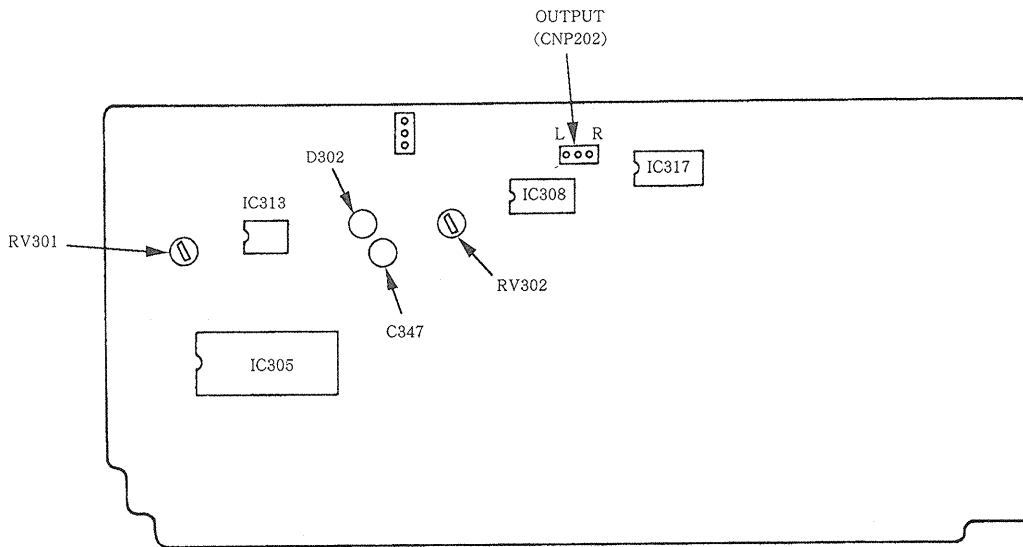

SUR board (Part surface)

SECTION 5 DIAGRAMS

5-1. IC BLOCK DIAGRAMS

IC102, 103 LC7821

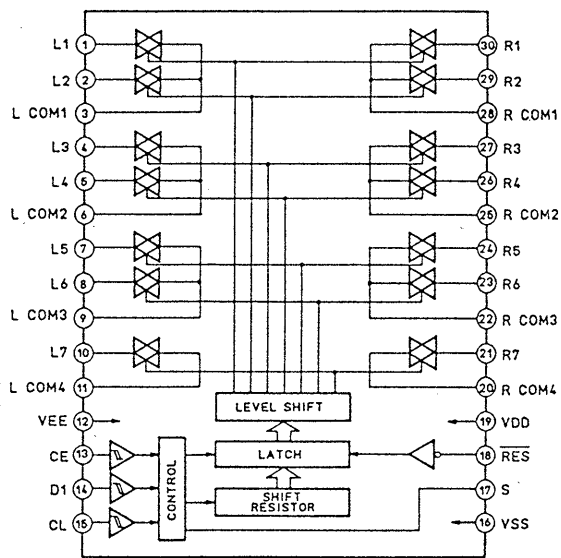

IC104, 105, 701, 702 LC7822

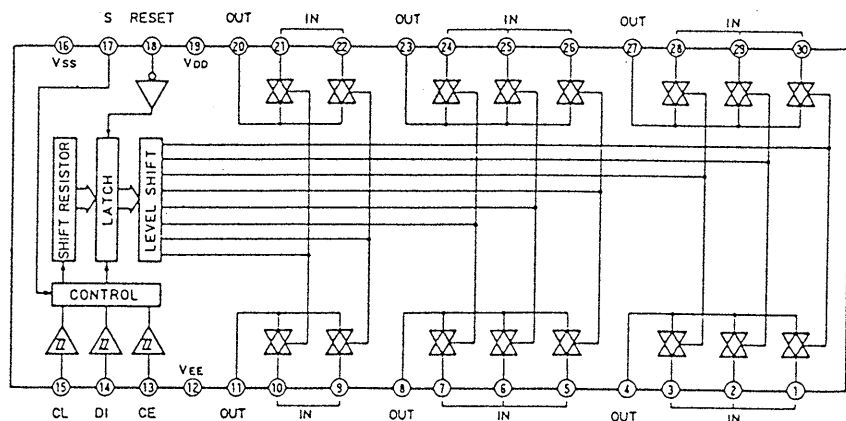

IC280, 281 NE571N-A

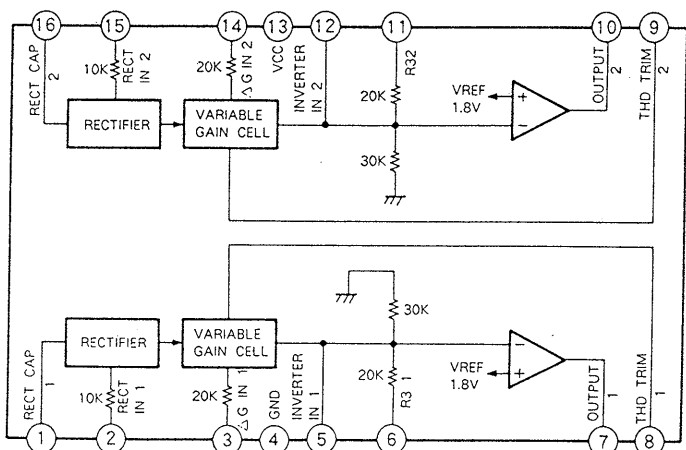

IC304 LA2775K

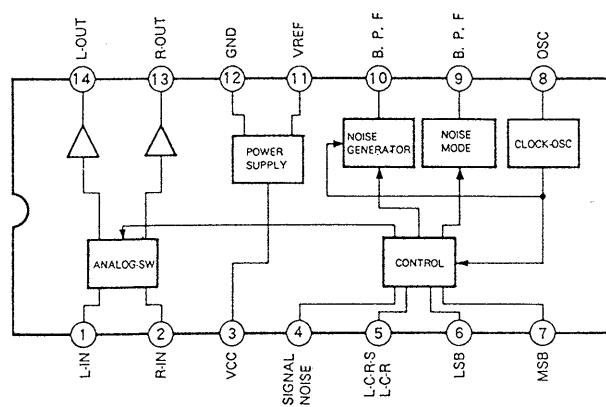

IC550, 555 LC7535

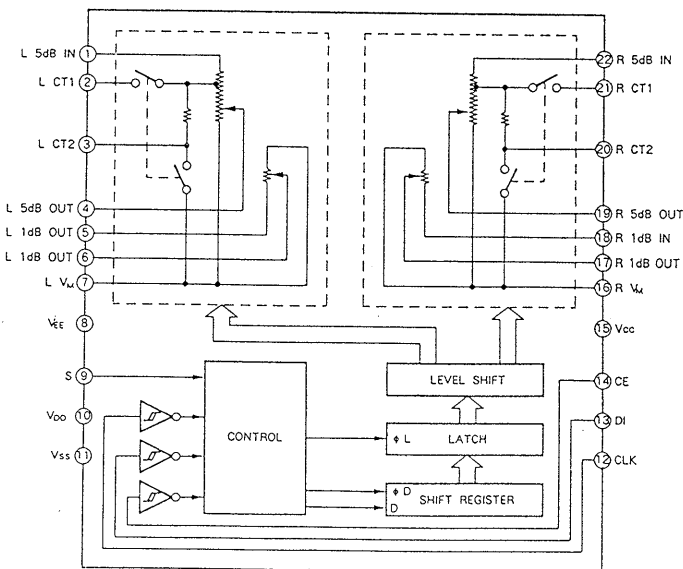

IC704, 705 LC7823

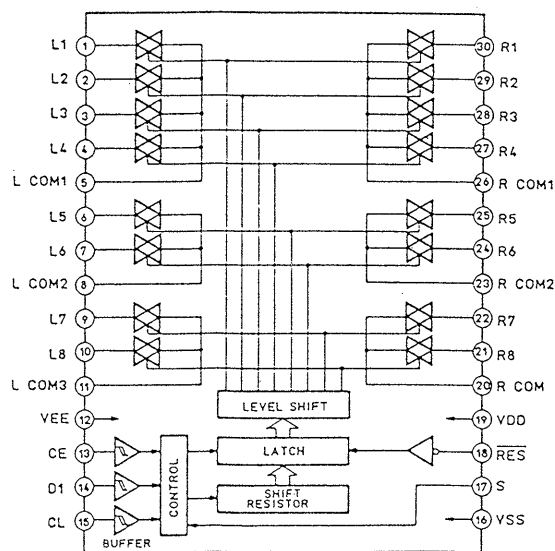

IC205 SN74HC08N

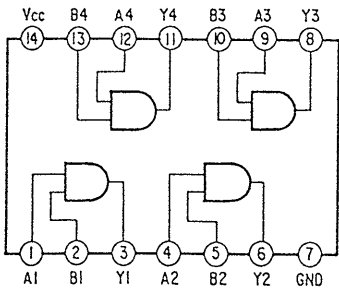

IC556 LB1639

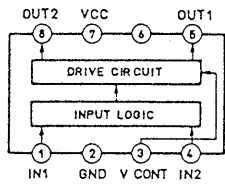

IC301 YM7128

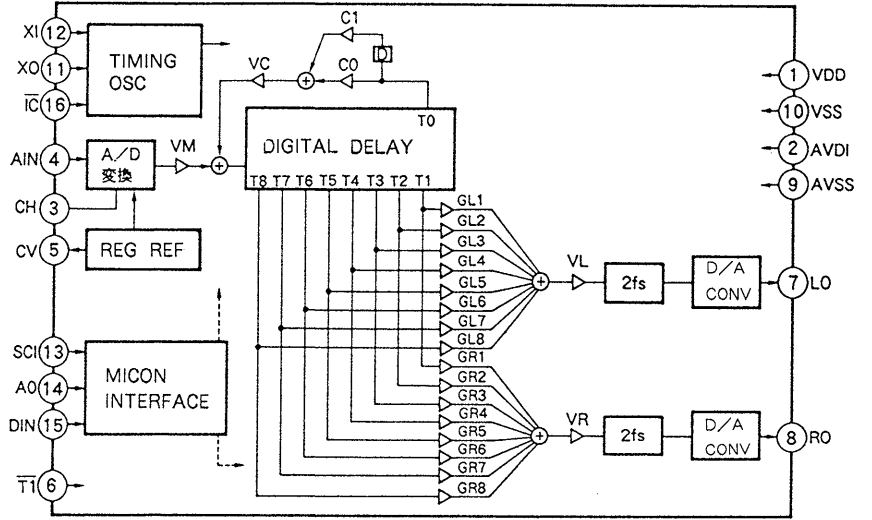

IC305 LA2770K

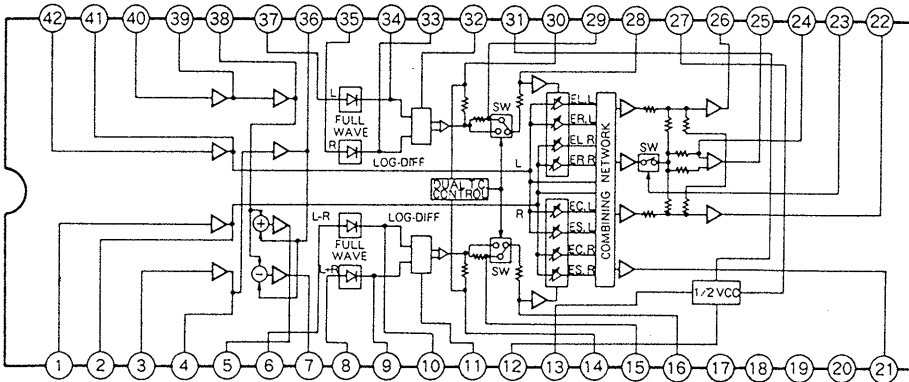

IC801 STK-4152 II

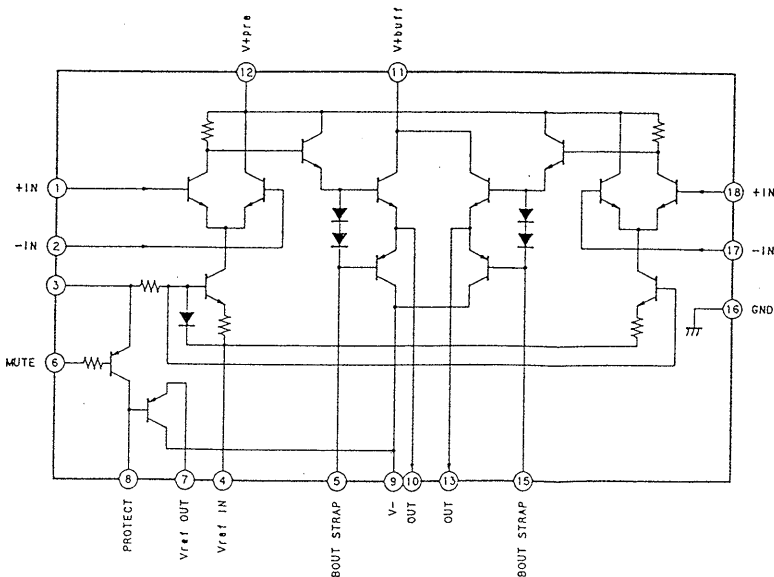

IC302 TC4052BPHB

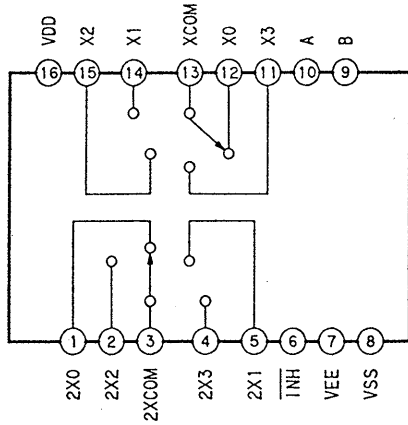

IC307, 308, 309 LC4966

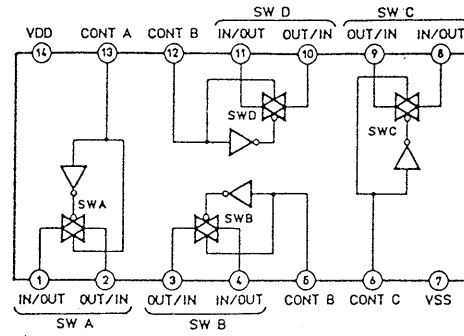

IC306 LA2730K

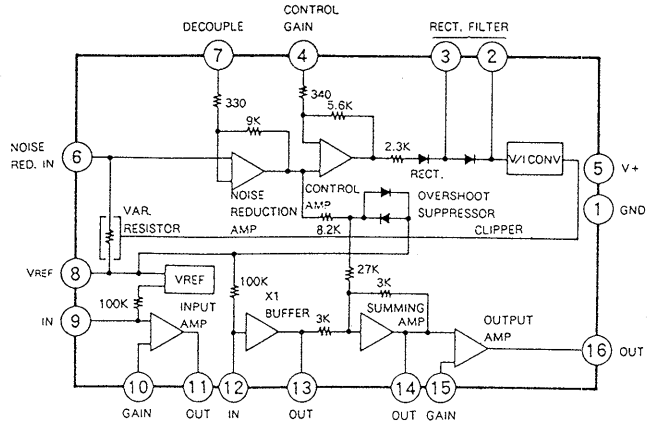

IC310 M51523AL

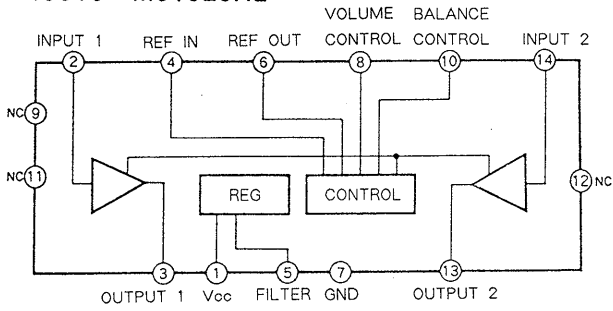

5-2. CIRCUIT BOARDS LOCATION

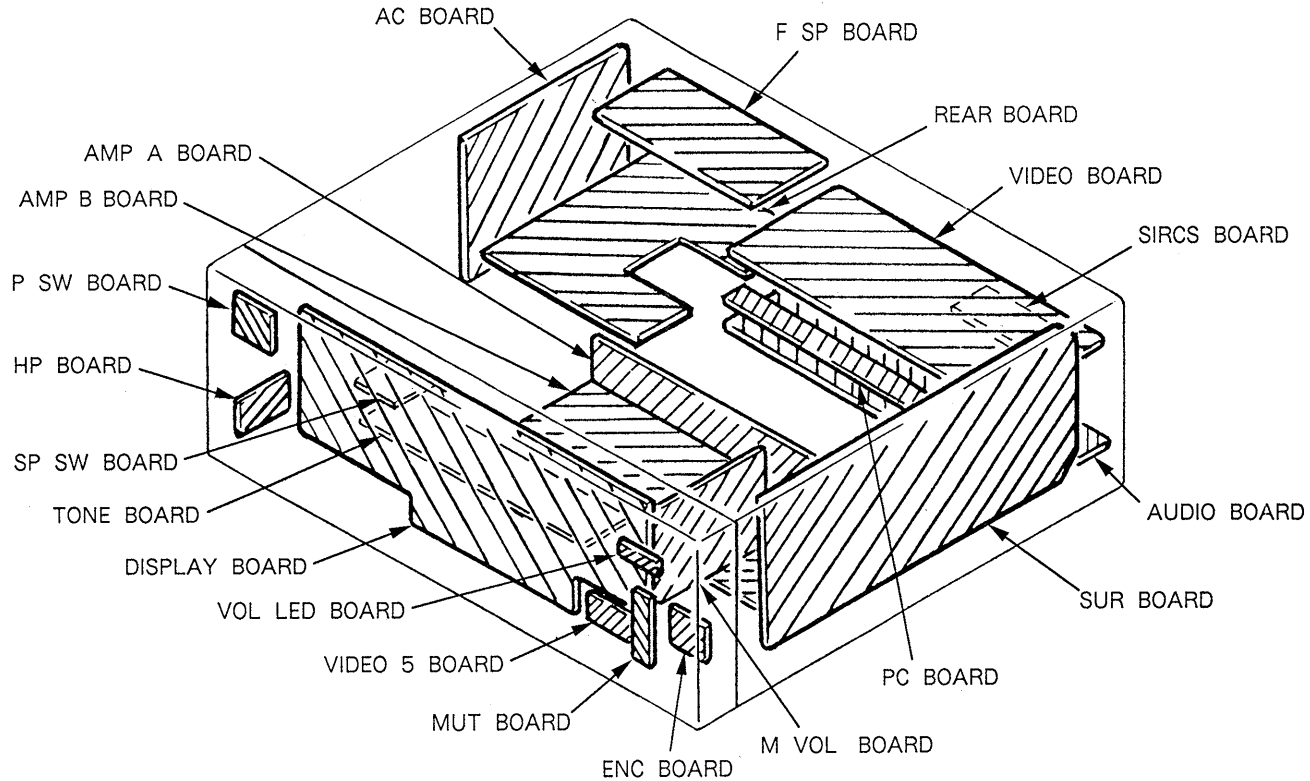

• SEMICONDUCTOR LEAD LAYOUTS

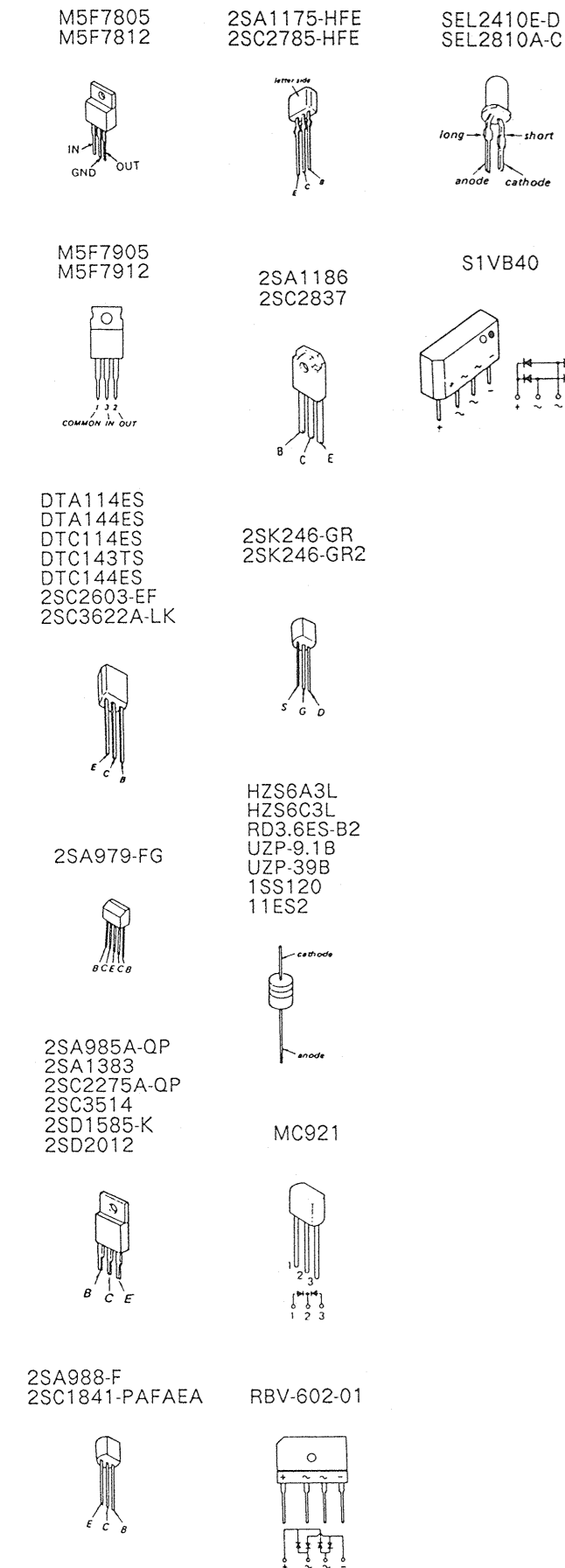

• SEMICONDUCTOR LOCATION

Ref. No.	Location	Ref. No.	Location
D301	G-3	IC702	D-19
D302	G-9	IC703	C-21
D303	G-9	IC704	D-17
D304	F-9	IC705	D-14
D701	C-20	IC706	C-14
D702	C-20	IC707	C-16
D703	B-19	IC1001	I-3
D1001	H-3	Q301	H-9
D1002	H-3	Q302	H-9
D1003	H-3	Q303	H-9
D1004	H-3	Q304	F-9
D1006	J-2	Q305	I-9
D1015	I-20	Q306	I-7
D1016	I-19	Q307	I-7
D1017	I-4	Q308	H-7
D1018	J-4	Q309	H-7
D1019	J-2	Q310	H-7
IC101	C-2	Q311	J-9
IC102	C-4	Q312	J-9
IC103	C-5	Q313	I-5
IC104	D-10	Q314	I-5
IC105	D-8	Q315	I-5
IC106	D-6	Q316	J-10
IC107	E-4	Q317	J-8
IC301	G-4	Q318	K-8
IC302	I-8	Q703	C-21
IC304	J-11	Q704	C-20
IC305	I-10	Q705	C-19
IC306	J-6	Q706	C-21
IC307	J-8	Q707	C-20
IC308	G-7	Q708	C-19
IC309	I-6	Q709	C-15
IC310	G-11	Q710	C-16
IC311	G-9	Q711	C-13
IC312	H-11	Q712	C-14
IC313	H-10	Q713	C-17
IC314	G-9	Q715	C-21
IC315	G-8	Q1001-A	J-3
IC316	G-3	Q1010	I-19
IC317	G-5	Q1011	I-20
IC318	J-7	Q1012	I-20
IC701	E-21	Q1013	H-5

Note :
 ○ : parts extracted from the component side.
 ● : parts extracted from the conductor side.
 ■ : parts mounted on the conductor side.
 ▨ : Pattern on the side which is seen.

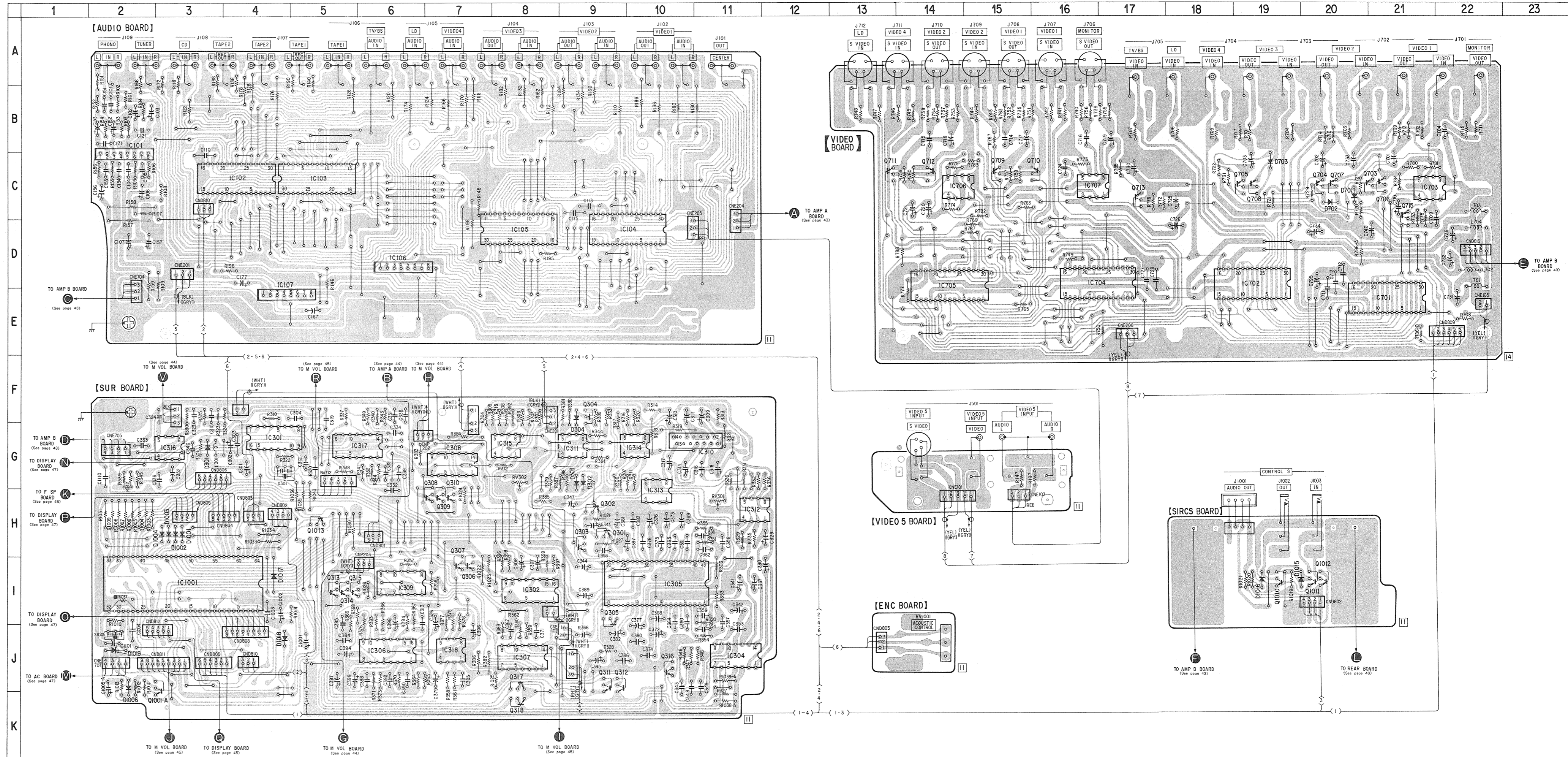

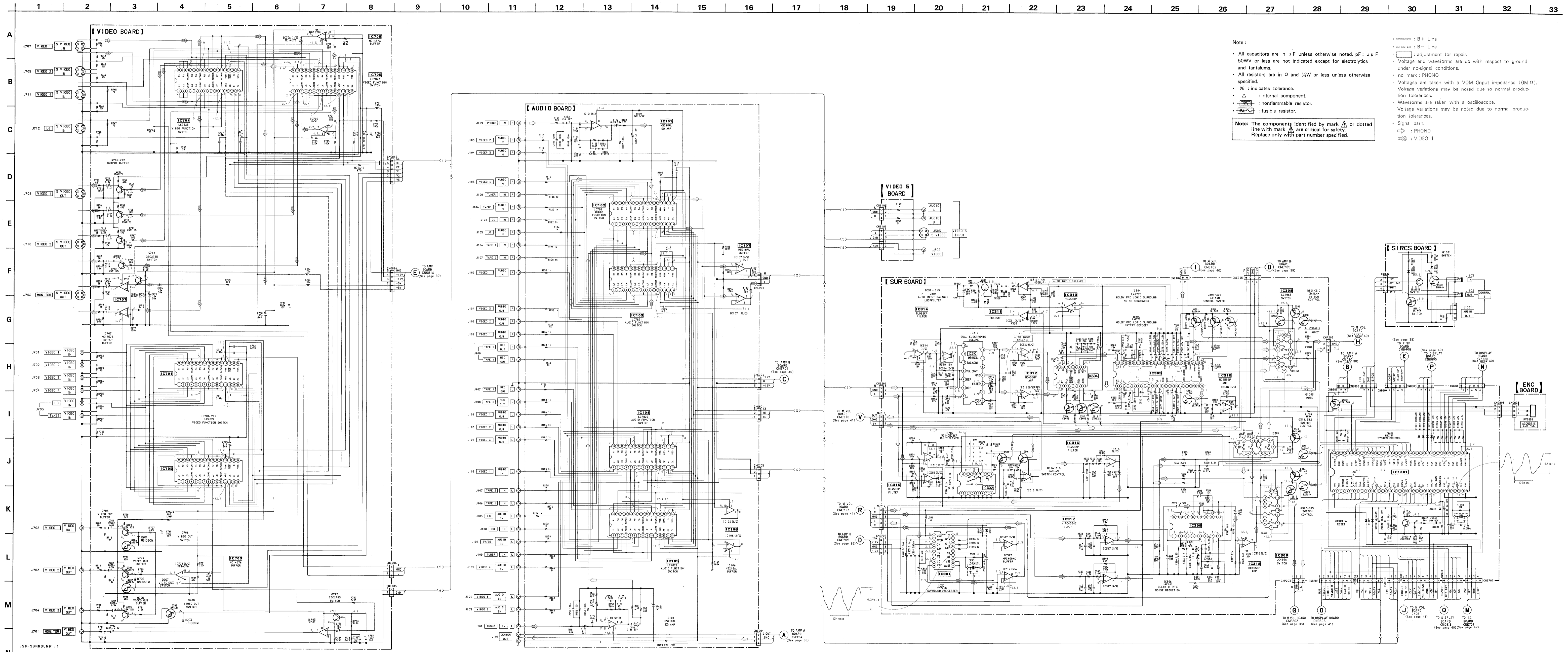

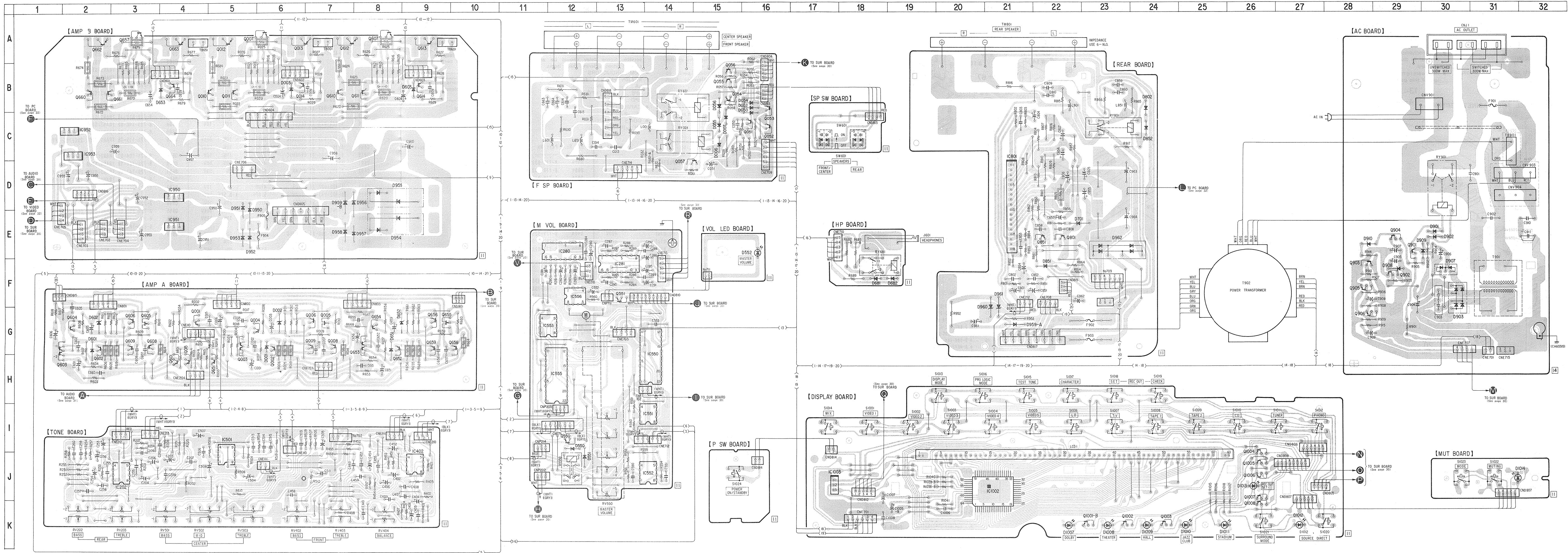

SEMICONDUCTOR LOCATION

Ref. No.	Location	Ref. No.	Location	Ref. No.	Location
D001	G-6	IC202	J-3	Q612	A-7
D002	G-6	IC280	E-12	Q613	A-9
D003	B-6	IC281	F-13	Q614	B-9
D006	C-15	IC402	J-9	Q651	H-5
D007	C-15	IC501	J-5	Q652	G-8
D050	C-16	IC550	H-14	Q653	G-8
D052	B-16	IC551	I-14	Q654	G-8
D054	B-16	IC552	J-14	Q655	G-9
D055	C-15	IC553	Q-12	Q656	G-9
D056	B-15	IC555	H-12	Q657	A-3
D550	I-12	IC556	F-12	Q658	G-10
D551	J-12	IC801	D-21	Q659	G-9
D552	E-16	IC950	D-4	Q660	B-2
D601	G-2	IC951	E-4	Q661	B-2
D602	G-2	IC952	C-2	Q662	A-2
D603	B-9	IC953	C-2	Q663	A-4
D651	G-8	IC1002	J-21	Q664	B-4
D652	G-8	IC1003	J-17	Q801	E-22
D653	B-4			Q851	E-22
D681	F-18			Q901	E-29
D682	F-19	Q001	G-4	Q902	F-29
D701	E-22	Q002	G-6	Q903	F-28
D802	B-24	Q003	G-5	Q904	E-29
D851	F-22	Q004	G-5	Q905	F-28
D852	C-24	Q005	G-7	Q906	G-28
D901	E-30	Q006	G-7	Q1001-B	K-23
D902	E-30	Q007	A-5	Q1002	K-23
D903	G-30	Q008	G-7	Q1003	K-24
D907	F-30	Q009	G-7	Q1004	J-26
D908	F-29	Q010	B-5	Q1005	J-26
D909	E-30	Q011	B-5	Q1006	J-26
D910	E-28	Q012	A-5	Q1007	J-26
D950	E-5	Q013	A-6	Q1008	K-26
D951	D-5	Q014	B-6		
D952	E-5	Q015	H-4		
		Q051	C-16		
D953	E-5	Q052	C-16		
D954	E-8	Q053	C-16		
D955	D-8	Q054	B-15		
D956	D-7	Q055	B-15		
D957	E-7	Q056	B-15		
D958	E-7	Q057	D-14		
D959-A	G-21	Q550	I-12		
D959-B	D-7	Q551	F-13		
D960	G-21	Q601	H-4		
D961	G-21	Q602	G-2		
D962	E-23	Q603	G-1		
D1007	K-22	Q604	G-2		
D1008	K-23	Q605	G-3		
D1009	K-24	Q606	G-3		
D1010	K-25	Q607	A-8		
D1011	K-25	Q608	G-3		
D1012	K-27	Q609	G-3		
D1013	J-26	Q610	B-7		
D1014	J-31	Q611	B-8		

- : parts extracted from the component side.
- : parts extracted from the conductor side.
- : parts mounted on the conductor side.
- ▨ : Pattern on the side which is seen.

6-2. CHASSIS SECTION

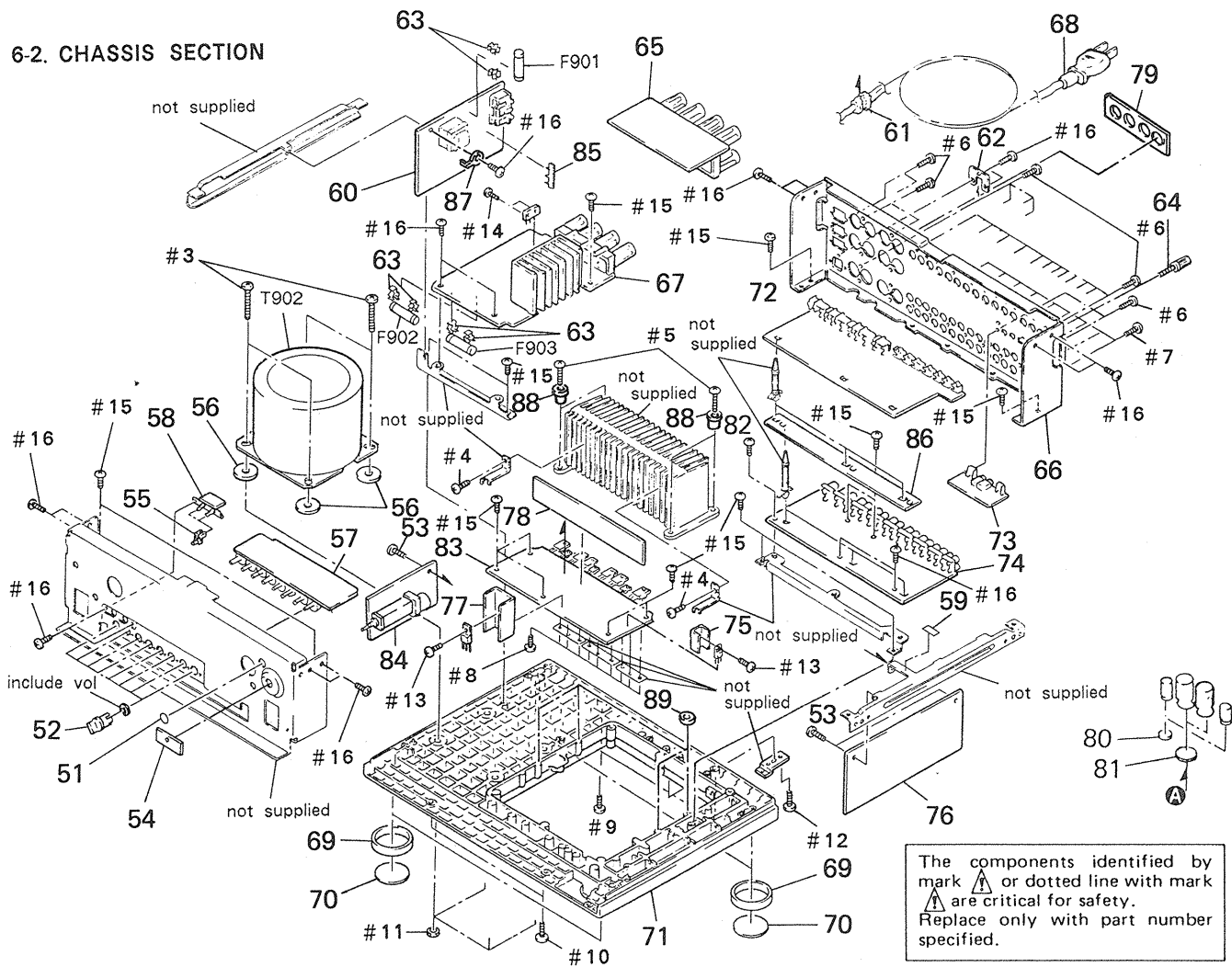

Ref. No.	Part No.	Description	Remark
51	* 4-908-892-01	SPACER	
52	4-922-531-51	KNOB (A TYPE), LOV (AV650G)	
52	4-922-531-01	KNOB (A TYPE), LOV (AV650)	
53	4-886-821-11	SCREW, S TIGHT, +PTTWH 3X6	
54	* 1-637-645-11	VOL LED BOARD	
55	4-923-879-11	BUTTON (DIA. 4) (AV650G)	
55	4-923-879-01	BUTTON (DIA. 4) (AV650)	
56	4-885-984-21	WASHER	
57	* A-4341-297-A	TONE BOARD, COMPLETE	
58	* 1-637-639-11	SP SW BOARD	
59	3-831-441-XX	CUSHION (25X15X0.3)	
60	* A-4345-313-A	AC BOARD, COMPLETE (AV650G)	
60	* A-4345-484-A	AC BOARD, COMPLETE (AV650)	
61	2-352-626-01	BUSHING, CORD (AV650G)	
61	4-916-783-01	BUSHING, CORD (AV650)	
62	* 4-923-873-01	BRACKET, CORD STOPPER	
63	1-533-225-11	HOLDER, FUSE	
64	* 4-941-033-01	SCREW, FIXED, FEEDER	
65	* A-4341-303-A	F SP BOARD, COMPLETE	
66	* 4-941-901-01	PANEL, BACK (AV650G)	
66	* 4-941-901-11	PANEL, BACK (AV650)	
67	* A-4341-302-A	REAR BOARD, COMPLETE	
68	⚠ 1-559-297-31	CORD, POWER (AV650G)	
68	⚠ 1-559-479-11	CORD, POWER (AV650)	
69	4-931-967-11	RING, ORNAMENTAL (AV650G)	
69	4-931-967-02	RING, ORNAMENTAL (AV650)	

Ref. No.	Part No.	Description	Remark
70	* 4-923-850-01	FOOT (DIA. 46)	
71	* 4-931-946-21	CHASSIS, MAIN	
72	* A-4341-298-A	VIDEO BOARD, COMPLETE	
73	* 1-637-652-11	SIRCS BOARD	
74	* A-4341-299-A	AUDIO BOARD, COMPLETE	
75	* 3-309-144-21	HEAT SINK	
76	* A-4341-301-A	SUR BOARD, COMPLETE	
77	* 4-880-403-11	HEAT SINK	
78	* A-4341-308-A	AMP (A) BOARD, COMPLETE	
79	* 4-924-098-81	HOLDER, PC BOARD	
80	* 4-942-408-01	SPACER (DIA. 30)	
81	* 4-942-409-01	SPACER (DIA. 40)	
83	* A-4345-630-A	AMP (B) BOARD, COMPLETE	
84	* A-4341-300-A	M VOL BOARD, COMPLETE	
85	1-569-007-11	ADAPTER, CONVERSION 2P	
86	* 1-637-651-11	PC BOARD	
87	4-870-539-00	PLATE, GROUND	
88	* 4-945-934-01	COLLAR (AV650)	
89	* 4-945-935-01	SPEACER (AV650)	
F901	⚠ 1-532-350-00	FUSE, TIME-LAG (4A) (AV650G)	
F901	⚠ 1-532-749-11	FUSE, GLASS TUBE (8A) (AV650)	
F902	⚠ 1-532-746-11	FUSE, GLASS TUBE (4A) (AV650G)	
F902	⚠ 1-532-746-11	FUSE, GLASS TUBE (4A) (AV650)	
F903	⚠ 1-532-746-11	FUSE, GLASS TUBE (4A) (AV650G)	
F903	⚠ 1-532-746-11	FUSE, GLASS TUBE (4A) (AV650)	
T901	⚠ 1-448-517-21	TRANSFORMER, POWER (AV650)	
T902	⚠ 1-450-509-11	TRANSFORMER, POWER (AV650G)	
T902	⚠ 1-450-561-11	TRANSFORMER, POWER (AV650)	

SECTION 7 ELECTRICAL PARTS LIST

AC

NOTE:

- Due to standardization, replacements in the parts list may be different from the parts specified in the diagrams or the components used on the set.
- -XX, -X mean standardized parts, so they may have some difference from the original one.
- RESISTORS
All resistors are in ohms
METAL: Metal-film resistor
METAL OXIDE: Metal Oxide-film resistor
F: nonflammable

- Items marked "*" are not stocked since they are seldom required for routine service. Some delay should be anticipated when ordering these items.
- SEMICONDUCTORS
In each case, u: μ , for example:
uA.....: μ A....., uPA.....: μ PA.....
uPB.....: μ PB....., uPC.....: μ PC.....
uPD.....: μ PD.....
- CAPACITORS
uF: μ F
- COILS
uH: μ H

The components identified by mark Δ or dotted line with mark Δ are critical for safety. Replace only with part number specified.

When indicating parts by reference number, please include the board name.

- AV-650: US model
- AV-650G: E model

Ref. No.	Part No.	Description	Remark		
	*A-4345-313-A	AC BOARD, COMPLETE	*****		
	1-533-225-11	HOLDER, FUSE			
	1-560-242-11	BUS BAR 3P			
	4-870-539-00	PLATE, GROUND			
< CAPACITOR >					
C901	1-161-744-00	CERAMIC	0.01uF		400V
C902	1-161-744-00	CERAMIC	0.01uF		400V
C903	1-102-394-11	CERAMIC	0.01uF		250V
C904	1-124-636-00	ELECT	3300uF	20%	25V
C905	1-124-907-11	ELECT	10uF	20%	50V
C906	1-124-903-11	ELECT	1uF	20%	50V
C907	1-124-907-11	ELECT	10uF	20%	50V
C908	1-124-464-11	ELECT	0.22uF	20%	50V
C909	1-124-903-11	ELECT	1uF	20%	50V
C910	1-161-742-00	CERAMIC	0.0022uF	20%	400V
C911	1-161-742-00	CERAMIC	0.0022uF	20%	400V
< CONNECTOR >					
CNE707 *	1-564-507-11	PLUG, CONNECTOR 4P			
CNE715 *	1-564-506-11	PLUG, CONNECTOR 3P			
CNJ1	Δ 1-540-043-31	OUTLET, AC (NONPOAR) (3P)			
CNV901 *	1-564-321-00	PIN, CONNECTOR 2P			
CNV903 *	1-564-687-11	PIN, CONNECTOR 3P			
CNV904 *	1-564-687-11	PIN, CONNECTOR 3P			
< DIODE >					
D901	8-719-912-20	DIODE 1SS120			
D902	8-719-912-20	DIODE 1SS120			
D903	8-719-511-40	DIODE S1VB40			
D907	8-719-000-06	DIODE MC921			

Ref. No.	Part No.	Description	Remark		
D908	8-719-933-41	DIODE HZS6C3L			
D909	8-719-933-41	DIODE HZS6C3L			
D910	8-719-010-23	DIODE UZ-3.6BSB			
< TRANSISTOR >					
Q901	8-729-620-05	TRANSISTOR 2SC2603-EF			
Q902	8-729-209-15	TRANSISTOR 2SD2012			
Q903	8-729-119-76	TRANSISTOR 2SA1175-HFE			
Q904	8-729-620-05	TRANSISTOR 2SC2603-EF			
Q905	8-729-119-76	TRANSISTOR 2SA1175-HFE			
Q906	8-729-620-05	TRANSISTOR 2SC2603-EF			
< RESISTOR >					
R901	1-249-425-11	CARBON	4.7K	5%	1/4W
R902	1-249-396-11	CARBON	18	5%	1/6W
R903	1-249-417-11	CARBON	1K	5%	1/4W
R904	1-249-439-11	CARBON	68K	5%	1/4W
R905	1-249-429-11	CARBON	10K	5%	1/4W
R906	1-249-426-11	CARBON	5.6K	5%	1/4W
R907	1-249-429-11	CARBON	10K	5%	1/4W
R908	1-249-426-11	CARBON	5.6K	5%	1/4W
R909	1-249-417-11	CARBON	1K	5%	1/4W
R913	1-249-429-11	CARBON	10K	5%	1/4W
R914	1-249-417-11	CARBON	1K	5%	1/4W
R915	1-249-401-11	CARBON	47	5%	1/4W
< RELAY >					
RY901	1-515-617-11	RELAY			
< TRANSFORMER >					
T901	Δ 1-449-071-11	TRANSFORMER, POWER (AV650G)			
< TERMINAL >					
TB901	1-560-595-00	TERMINAL (WHITH BASE) (AV650)			

AMP(A)

Ref. No.	Part No.	Description	Remark		
* A-4341-308-A AMP (A) BOARD, COMPLETE *****					
< CAPACITOR >					
C001	1-126-163-11	ELECT	4.7uF	20%	50V
C002	1-130-469-00	MYLAR	680PF	5%	50V
C003	1-126-022-11	ELECT	47uF	20%	10V
C005	1-102-942-00	CERAMIC	5.0PF	+0.5PF	50V
C006	1-126-022-11	ELECT	47uF	20%	10V
C007	1-161-959-00	CERAMIC	22PF	10%	500V
C008	1-161-959-00	CERAMIC	22PF	10%	500V
C015	1-162-286-31	CERAMIC	220PF	10%	50V
C601	1-126-163-11	ELECT	4.7uF	20%	50V
C602	1-130-469-00	MYLAR	680PF	5%	50V
C603	1-126-022-11	ELECT	47uF	20%	10V
C605	1-102-942-00	CERAMIC	5.0PF	+0.5PF	50V
C606	1-126-022-11	ELECT	47uF	20%	10V
C607	1-161-959-00	CERAMIC	22PF	10%	500V
C608	1-161-959-00	CERAMIC	22PF	10%	500V
C615	1-162-286-31	CERAMIC	220PF	10%	50V
C651	1-126-163-11	ELECT	4.7uF	20%	50V
C652	1-130-469-00	MYLAR	680PF	5%	50V
C653	1-126-022-11	ELECT	47uF	20%	10V
C655	1-102-942-00	CERAMIC	5.0PF	+0.5PF	50V
C656	1-126-022-11	ELECT	47uF	20%	10V
C657	1-161-959-00	CERAMIC	22PF	10%	500V
C658	1-161-959-00	CERAMIC	22PF	10%	500V
C655	1-162-286-31	CERAMIC	220PF	10%	50V
< CONNECTOR >					
CN801	* 1-565-481-11	CONNECTOR, BOARD TO BOARD 5P			
CN802	* 1-565-481-11	CONNECTOR, BOARD TO BOARD 5P			
CN803	* 1-565-481-11	CONNECTOR, BOARD TO BOARD 5P			
CNE204	* 1-564-506-11	PLUG, CONNECTOR 3P			
CNE706	* 1-564-506-11	PLUG, CONNECTOR 3P			
< DIODE >					
D001	8-719-912-20	DIODE 1SS120			
D002	8-719-933-35	DIODE HZS6A3L			
D601	8-719-912-20	DIODE 1SS120			
D602	8-719-933-35	DIODE HZS6A3L			
D651	8-719-912-20	DIODE 1SS120			
D652	8-719-933-35	DIODE HZS6A3L			
< TRANSISTOR >					
Q001	8-729-141-26	TRANSISTOR 2SC3622A-LK			
Q002	8-729-119-78	TRANSISTOR 2SC2785-HFE			
Q003	8-729-620-18	TRANSISTOR 2SA979-FG			
Q004	8-729-140-82	TRANSISTOR 2SA988-PAFAEA			

Ref. No.	Part No.	Description	Remark		
Q005	8-729-201-56	TRANSISTOR 2SK246-GR2			
Q006	8-729-119-78	TRANSISTOR 2SC2785-HFE			
Q008	8-729-104-91	TRANSISTOR 2SA1383-Q			
Q009	8-729-104-18	TRANSISTOR 2SC3514-Q			
Q015	8-729-141-26	TRANSISTOR 2SC3622A-LK			
Q601	8-729-141-26	TRANSISTOR 2SC3622A-LK			
Q602	8-729-119-78	TRANSISTOR 2SC2785-HFE			
Q603	8-729-620-18	TRANSISTOR 2SA979-FG			
Q604	8-729-140-82	TRANSISTOR 2SA988-PAFAEA			
Q605	8-729-201-56	TRANSISTOR 2SK246-GR2			
Q606	8-729-119-78	TRANSISTOR 2SC2785-HFE			
Q608	8-729-104-91	TRANSISTOR 2SA1383-Q			
Q609	8-729-104-18	TRANSISTOR 2SC3514-Q			
Q651	8-729-141-26	TRANSISTOR 2SC3622A-LK			
Q652	8-729-119-78	TRANSISTOR 2SC2785-HFE			
Q653	8-729-620-18	TRANSISTOR 2SA979-FG			
Q654	8-729-140-82	TRANSISTOR 2SA988-PAFAEA			
Q655	8-729-201-56	TRANSISTOR 2SK246-GR2			
Q656	8-729-119-78	TRANSISTOR 2SC2785-HFE			
Q658	8-729-104-91	TRANSISTOR 2SA1383-Q			
Q659	8-729-104-18	TRANSISTOR 2SC3514-Q			
< RESISTOR >					
R001	1-247-713-11	CARBON	1K	5%	1/4W
R002	1-247-721-11	CARBON	4.7K	5%	1/4W
R003	1-247-713-11	CARBON	1K	5%	1/4W
R004	1-249-497-11	CARBON	33K	5%	1/4W
R005	1-247-704-11	CARBON	220	5%	1/4W
R006	1-247-704-11	CARBON	220	5%	1/4W
R007	1-247-711-11	CARBON	680	5%	1/4W
R008	1-247-717-11	CARBON	2.2K	5%	1/4W
R009	1-249-460-11	CARBON	15K	5%	1/4W
R010	1-247-706-11	CARBON	330	5%	1/4W
R011	1-249-462-11	CARBON	22K	5%	1/4W
R012	1-249-497-11	CARBON	33K	5%	1/4W
R013	1-247-725-11	CARBON	10K	5%	1/4W
R014	1-247-692-11	CARBON	22	5%	1/4W
R017	1-249-709-11	CARBON	33K	5%	1/2W
R018	1-247-716-11	CARBON	1.8K	5%	1/4W
R019	1-247-692-11	CARBON	22	5%	1/4W
R033	1-249-465-11	CARBON	47K	5%	1/4W
R034	1-247-721-11	CARBON	4.7K	5%	1/4W
R601	1-247-713-11	CARBON	1K	5%	1/4W
R602	1-247-721-11	CARBON	4.7K	5%	1/4W
R603	1-247-713-11	CARBON	1K	5%	1/4W
R604	1-249-497-11	CARBON	33K	5%	1/4W
R605	1-247-704-11	CARBON	220	5%	1/4W
R606	1-247-704-11	CARBON	220	5%	1/4W

AMP(A)

AMP(B)

Ref. No.	Part No.	Description	Remark		
R607	1-247-711-11	CARBON	680	5%	1/4W
R608	1-247-717-11	CARBON	2.2K	5%	1/4W
R609	1-249-460-11	CARBON	15K	5%	1/4W
R610	1-247-706-11	CARBON	330	5%	1/4W
R611	1-249-462-11	CARBON	22K	5%	1/4W
R612	1-249-497-11	CARBON	33K	5%	1/4W
R613	1-247-725-11	CARBON	10K	5%	1/4W
R614	1-247-692-11	CARBON	22	5%	1/4W
R617	1-249-709-11	CARBON	33K	5%	1/2W
R618	1-247-716-11	CARBON	1.8K	5%	1/4W
R619	1-247-692-11	CARBON	22	5%	1/4W
R633	1-249-465-11	CARBON	47K	5%	1/4W
R651	1-247-713-11	CARBON	1K	5%	1/4W
R652	1-247-721-11	CARBON	4.7K	5%	1/4W
R653	1-247-713-11	CARBON	1K	5%	1/4W
R654	1-249-497-11	CARBON	33K	5%	1/4W
R655	1-247-704-11	CARBON	220	5%	1/4W
R656	1-247-704-11	CARBON	220	5%	1/4W
R657	1-247-711-11	CARBON	680	5%	1/4W
R658	1-247-717-11	CARBON	2.2K	5%	1/4W
R659	1-249-460-11	CARBON	15K	5%	1/4W
R660	1-247-706-11	CARBON	330	5%	1/4W
R661	1-249-462-11	CARBON	22K	5%	1/4W
R662	1-249-497-11	CARBON	33K	5%	1/4W
R663	1-247-725-11	CARBON	10K	5%	1/4W
R664	1-247-692-11	CARBON	22	5%	1/4W
R667	1-249-709-11	CARBON	33K	5%	1/2W
R668	1-247-716-11	CARBON	1.8K	5%	1/4W
R669	1-247-692-11	CARBON	22	5%	1/4W
R683	1-249-465-11	CARBON	47K	5%	1/4W

* A-4345-630-A AMP (B) BOARD, COMPLETE					

* 3-309-144-21 HEAT SINK					
* 4-880-403-11 HEAT SINC					
7-682-548-04 SCREW +BVTT 3X8 (S)					
< CAPACITOR >					
C004	1-126-022-11	ELECT	47uF	20%	10V
C009	1-136-165-00	FILM	0.1uF	5%	50V
C604	1-126-022-11	ELECT	47uF	20%	10V
C609	1-136-165-00	FILM	0.1uF	5%	50V
C654	1-126-022-11	ELECT	47uF	20%	10V
C659	1-136-165-00	FILM	0.1uF	5%	50V
C950	1-126-042-11	ELECT	3300uF	20%	35V
C950	1-125-661-11	CAP, ELECT	5600MF		
C951	1-126-042-11	ELECT	3300uF	20%	35V
C952	1-126-012-11	ELECT	470uF	20%	16V

Ref. No.	Part No.	Description	Remark		
C953	1-126-012-11	ELECT	470uF	20%	16V
C955	1-124-997-11	ELECT	470uF	20%	10V
C956	1-124-997-11	ELECT	470uF	20%	10V
C957	1-125-460-11	CAP, ELECT	12000MF		
C958	1-125-460-11	CAP, ELECT	12000MF		
C959	1-125-661-11	CAP, ELECT	5600MF		
< CONNECTOR >					
CND601	* 1-560-552-00	PIN, CONNECTOR	5P		
CND602	* 1-560-552-00	PIN, CONNECTOR	5P		
CND603	* 1-560-552-00	PIN, CONNECTOR	5P		
CND604	* 1-564-243-00	PIN, CONNECTOR	6P		
CND605	* 1-564-915-11	PIN, CONNECTOR	7P		
CND816	* 1-564-339-71	PIN, CONNECTOR	5P		
CNE702	* 1-564-506-11	PLUG, CONNECTOR	3P		
CNE703	* 1-564-507-11	PLUG, CONNECTOR	4P		
CNE704	* 1-564-506-11	PLUG, CONNECTOR	3P		
CNE705	* 1-564-507-11	PLUG, CONNECTOR	4P		
< DIODE >					
D003	8-719-912-20	DIODE	1SS120		
D603	8-719-912-20	DIODE	1SS120		
D653	8-719-912-20	DIODE	1SS120		
D950	8-719-200-82	DIODE	11ES2		
D951	8-719-200-82	DIODE	11ES2		
D952	8-719-200-82	DIODE	11ES2		
D953	8-719-200-82	DIODE	11ES2		
D954	8-719-210-37	DIODE	D301		
D955	8-719-210-37	DIODE	D301		
D956	8-719-200-82	DIODE	11ES2		
D957	8-719-200-82	DIODE	11ES2		
D958	8-719-200-82	DIODE	11ES2		
D959	8-719-200-82	DIODE	11ES2		
< FUSE >					
F904	1-532-846-21	LINK, IC			
F905	1-532-846-21	LINK, IC			
< IC >					
IC950	8-759-231-58	IC	TA7812S		
IC951	8-759-245-86	IC	TA7912S		
IC952	8-759-231-53	IC	TA7805S		
IC953	8-759-245-79	IC	TA7905S		
< TRANSISTOR >					
Q007	8-729-107-20	TRANSISTOR	2SD1585-K		
Q010	8-729-141-58	TRANSISTOR	2SC2275A-QP		
Q011	8-729-141-10	TRANSISTOR	2SA985A-QP		
Q012	8-729-383-73	TRANSISTOR	2SC2837		
Q013	8-729-318-63	TRANSISTOR	2SA1186		

AMP(B)

AUDIO

Ref. No.	Part No.	Description	Remark
Q014	8-729-140-82	TRANSISTOR 2SA988-PAFAEA	
Q607	8-729-107-26	TRANSISTOR 2SD1585-K	
Q610	8-729-141-58	TRANSISTOR 2SC2275A-QP	
Q611	8-729-141-10	TRANSISTOR 2SA985A-QP	
Q612	8-729-383-73	TRANSISTOR 2SC2837	
Q613	8-729-318-63	TRANSISTOR 2SA1186	
Q614	8-729-140-82	TRANSISTOR 2SA988-PAFAEA	
Q657	8-729-107-26	TRANSISTOR 2SD1585-K	
Q660	8-729-141-58	TRANSISTOR 2SC2275A-QP	
Q661	8-729-141-10	TRANSISTOR 2SA985A-QP	
Q662	8-729-383-73	TRANSISTOR 2SC2837	
Q663	8-729-318-63	TRANSISTOR 2SA1186	
Q664	8-729-108-14	TRANSISTOR 2SA988-F	
< RESISTOR >			
R015	1-249-556-11	CARBON 1.5K 5% 1/4W	
R016	1-247-710-11	CARBON 560 5% 1/4W	
R020	1-247-700-11	CARBON 100 5% 1/4W	
R021	1-249-465-11	CARBON 47K 5% 1/4W	
R022	1-247-700-11	CARBON 100 5% 1/4W	
R023	1-247-745-11	CARBON 330 5% 1/2W	
R024	1-249-455-11	CARBON 4.7 5% 1/4W	
R025	1-249-455-11	CARBON 4.7 5% 1/4W	
R026	△-1-217-611-00	RES. METAL PLATE 0.1	
R027	△-1-217-611-00	RES. METAL PLATE 0.1	
R028	1-249-556-11	CARBON 1.5K 5% 1/4W	
R029	1-249-460-11	CARBON 15K 5% 1/4W	
R035	1-249-460-11	CARBON 15K 5% 1/4W	
R615	1-249-556-11	CARBON 1.5K 5% 1/4W	
R616	1-247-710-11	CARBON 560 5% 1/4W	
R620	1-247-700-11	CARBON 100 5% 1/4W	
R621	1-249-465-11	CARBON 47K 5% 1/4W	
R622	1-247-700-11	CARBON 100 5% 1/4W	
R623	1-247-745-11	CARBON 330 5% 1/2W	
R624	1-249-455-11	CARBON 4.7 5% 1/4W	
R625	1-249-455-11	CARBON 4.7 5% 1/4W	
R626	△-1-217-611-00	RES. METAL PLATE 0.1	
R627	△-1-217-611-00	RES. METAL PLATE 0.1	
R628	1-249-556-11	CARBON 1.5K 5% 1/4W	
R629	1-249-460-11	CARBON 15K 5% 1/4W	
R635	1-249-460-11	CARBON 15K 5% 1/4W	
R665	1-249-556-11	CARBON 1.5K 5% 1/4W	
R666	1-247-710-11	CARBON 560 5% 1/4W	
R670	1-247-700-11	CARBON 100 5% 1/4W	
R671	1-249-465-11	CARBON 47K 5% 1/4W	
R672	1-247-700-11	CARBON 100 5% 1/4W	
R673	1-247-745-11	CARBON 330 5% 1/2W	
R674	1-249-455-11	CARBON 4.7 5% 1/4W	
R675	1-249-455-11	CARBON 4.7 5% 1/4W	

Ref. No.	Part No.	Description	Remark
R676	△-1-217-611-00	RES. METAL PLATE 0.1	
R677	△-1-217-611-00	RES. METAL PLATE 0.1	
R678	1-249-556-11	CARBON 1.5K 5% 1/4W	
R679	1-249-460-11	CARBON 15K 5% 1/4W	
R685	1-249-460-11	CARBON 15K 5% 1/4W	
< TERMINAL >			
TB001	* 1-508-809-00	BASE POST (14MM) 2P	
TB601	* 1-508-809-00	BASE POST (14MM) 2P	
TB651	* 1-508-809-00	BASE POST (14MM) 2P	

* A-4341-299-A AUDIO BOARD, COMPLETE			

< CAPACITOR >			
C101	1-102-973-00	CERAMIC 100PF 5% 50V	
C102	1-124-925-11	ELECT 2.2uF 20% 100V	
C103	1-124-126-00	ELECT 47uF 20% 10V	
C104	1-130-480-00	MYLAR 0.0056uF 5% 50V	
C105	1-130-473-00	MYLAR 0.0015uF 5% 50V	
C106	1-124-252-00	ELECT 0.33uF 20% 50V	
C107	1-124-477-11	ELECT 47uF 20% 25V	
C110	1-124-925-11	ELECT 2.2uF 20% 100V	
C113	1-162-306-11	CERAMIC 0.01uF 20% 16V	
C115	1-162-306-11	CERAMIC 0.01uF 20% 16V	
C117	1-126-163-11	ELECT 4.7uF 20% 50V	
C121	1-102-973-00	CERAMIC 100PF 5% 50V	
C151	1-102-973-00	CERAMIC 100PF 5% 50V	
C152	1-124-925-11	ELECT 2.2uF 20% 100V	
C153	1-124-126-00	ELECT 47uF 20% 10V	
C154	1-130-480-00	MYLAR 0.0056uF 5% 50V	
C155	1-130-473-00	MYLAR 0.0015uF 5% 50V	
C156	1-124-252-00	ELECT 0.33uF 20% 50V	
C157	1-124-477-11	ELECT 47uF 20% 25V	
C167	1-126-163-11	ELECT 4.7uF 20% 50V	
C171	1-102-973-00	CERAMIC 100PF 5% 50V	
< CONNECTOR >			
CND810	* 1-564-337-71	PIN, CONNECTOR 3P	
CNE201	* 1-564-506-11	PLUG, CONNECTOR 3P	
CNE204	* 1-564-506-11	PLUG, CONNECTOR 3P	
CNE205	* 1-564-506-11	PLUG, CONNECTOR 3P	
CNE704	* 1-564-506-11	PLUG, CONNECTOR 3P	

Note: The components identified by mark △ or dotted line with mark △ are critical for safety. Replace only with part number specified.

AUDIO	DISPLAY
-------	---------

Ref. No.	Part No.	Description	Remark
		< IC >	
IC101	8-759-634-50	IC M5218AL	
IC102	8-759-805-13	IC LC7821	
IC103	8-759-805-13	IC LC7821	
IC104	8-759-805-14	IC LC7822	
IC105	8-759-805-14	IC LC7822	
IC106	8-759-634-50	IC M5218AL	
IC107	8-759-634-50	IC M5218AL	
		< JACK >	
J101	1-565-352-51	JACK, PIN 2P	
J102	1-568-069-11	JACK, PIN 4P (VIDEO 1 AUDIO IN/OUT)	
J103	1-568-069-11	JACK, PIN 4P (VIDEO 2 AUDIO IN/OUT)	
J104	1-568-069-11	JACK, PIN 4P (VIDEO 3 AUDIO IN/OUT)	
J105	1-568-069-11	JACK, PIN 4P (LD/VIDEO 4 AUDIO IN)	
J106	1-568-069-11	JACK, PIN 4P (TV/TAPE 1 AUDIO IN)	
J107	1-568-069-11	JACK, PIN 4P (TAPE 1/TAPE 2 REC IN/OUT)	
J108	1-568-069-11	JACK, PIN 4P (CD/TAPE 2 REC IN/OUT)	
J109	1-568-069-11	JACK, PIN 4P (PHONO/TUNER IN)	
		< RESISTOR >	
R101	1-249-411-11	CARBON 330 5% 1/4W	
R102	1-249-441-11	CARBON 100K 5% 1/4W	
R103	1-249-441-11	CARBON 100K 5% 1/4W	
R104	1-249-416-11	CARBON 820 5% 1/4W	
R105	1-247-897-11	CARBON 560K 5% 1/4W	
R106	1-249-437-11	CARBON 47K 5% 1/4W	
R107	1-249-441-11	CARBON 100K 5% 1/4W	
R108	1-249-409-11	CARBON 220 5% 1/4W	
R109	1-249-409-11	CARBON 220 5% 1/4W	
R110	1-249-417-11	CARBON 1K 5% 1/4W	
R112	1-249-417-11	CARBON 1K 5% 1/4W	
R116	1-249-417-11	CARBON 1K 5% 1/4W	
R118	1-249-417-11	CARBON 1K 5% 1/4W	
R120	1-249-417-11	CARBON 1K 5% 1/4W	
R122	1-249-417-11	CARBON 1K 5% 1/4W	
R124	1-249-417-11	CARBON 1K 5% 1/4W	
R126	1-249-417-11	CARBON 1K 5% 1/4W	
R128	1-249-417-11	CARBON 1K 5% 1/4W	
R130	1-249-417-11	CARBON 1K 5% 1/4W	
R132	1-249-417-11	CARBON 1K 5% 1/4W	
R134	1-249-417-11	CARBON 1K 5% 1/4W	
R136	1-249-417-11	CARBON 1K 5% 1/4W	
R138	1-249-417-11	CARBON 1K 5% 1/4W	
R140	1-249-417-11	CARBON 1K 5% 1/4W	
R146	1-249-441-11	CARBON 100K 5% 1/4W	
R148	1-249-441-11	CARBON 100K 5% 1/4W	

Ref. No.	Part No.	Description	Remark
R151	1-249-411-11	CARBON 330 5% 1/4W	
R152	1-249-441-11	CARBON 100K 5% 1/4W	
R153	1-249-441-11	CARBON 100K 5% 1/4W	
R154	1-249-416-11	CARBON 820 5% 1/4W	
R155	1-247-897-11	CARBON 560K 5% 1/4W	
R156	1-249-437-11	CARBON 47K 5% 1/4W	
R157	1-249-441-11	CARBON 100K 5% 1/4W	
R158	1-249-409-11	CARBON 220 5% 1/4W	
R159	1-249-409-11	CARBON 220 5% 1/4W	
R160	1-249-417-11	CARBON 1K 5% 1/4W	
R162	1-249-417-11	CARBON 1K 5% 1/4W	
R166	1-249-417-11	CARBON 1K 5% 1/4W	
R168	1-249-417-11	CARBON 1K 5% 1/4W	
R170	1-249-417-11	CARBON 1K 5% 1/4W	
R172	1-249-417-11	CARBON 1K 5% 1/4W	
R174	1-249-417-11	CARBON 1K 5% 1/4W	
R176	1-249-417-11	CARBON 1K 5% 1/4W	
R178	1-249-417-11	CARBON 1K 5% 1/4W	
R180	1-249-417-11	CARBON 1K 5% 1/4W	
R182	1-249-417-11	CARBON 1K 5% 1/4W	
R184	1-249-417-11	CARBON 1K 5% 1/4W	
R186	1-249-417-11	CARBON 1K 5% 1/4W	
R188	1-249-417-11	CARBON 1K 5% 1/4W	
R190	1-249-417-11	CARBON 1K 5% 1/4W	
R195	1-249-429-11	CARBON 10K 5% 1/4W	
R196	1-249-441-11	CARBON 100K 5% 1/4W	
R198	1-249-441-11	CARBON 100K 5% 1/4W	

	* 1-637-634-11	DISPLAY BOARD	

	* 4-921-419-01	CUSHION (FL)	
	4-933-419-01	HOLDER (FL)	
		< CAPACITOR >	
C1005	1-124-257-00	ELECT 2.2uF 20% 50V	
C1006	1-162-282-31	CERAMIC 100PF 10% 50V	
C1007	1-124-907-11	ELECT 10uF 20% 50V	
C1008	1-161-379-00	CERAMIC 0.01uF 30% 16V	
		< CONNECTOR >	
CND806	* 1-564-243-00	PIN, CONNECTOR 6P	
CND807	* 1-560-552-00	PIN, CONNECTOR 5P	
CND812	* 1-560-552-00	PIN, CONNECTOR 5P	
CND814	* 1-564-495-11	PIN, CONNECTOR 2P	
CNE701	* 1-564-505-11	PLUG, CONNECTOR 2P	

DISPLAY **ENC** **F SP**

Ref. No.	Part No.	Description	Remark
< DIODE >			
D1007	8-719-301-49	DIODE SEL2810A (DORBY)	
D1008	8-719-301-49	DIODE SEL2810A (THEATER)	
D1009	8-719-301-49	DIODE SEL2810A (HALL)	
D1010	8-719-301-49	DIODE SEL2810A (JAZZ CLUB)	
D1011	8-719-301-49	DIODE SEL2810A (STADIUM)	
D1012	8-719-301-49	DIODE SEL2810A (SOURCE DIRECT)	
D1013	8-719-301-49	DIODE SEL2810A (REC OUT SET)	
< INDICATOR >			
FL1001	1-519-628-11	INDICATOR TUBE, FLUORESCENT	
< IC >			
IC1002	8-759-505-99	IC MSC7128	
IC1003	8-749-920-83	IC GP1U52XB	
< TRANSISTOR >			
Q1001	8-729-900-80	TRANSISTOR DTC114ES	
Q1002	8-729-900-80	TRANSISTOR DTC114ES	
Q1003	8-729-900-80	TRANSISTOR DTC114ES	
Q1004	8-729-900-80	TRANSISTOR DTC114ES	
Q1005	8-729-900-80	TRANSISTOR DTC114ES	
Q1006	8-729-900-80	TRANSISTOR DTC114ES	
Q1007	8-729-900-80	TRANSISTOR DTC114ES	
Q1008	8-729-900-80	TRANSISTOR DTC114ES	
< RESISTOR >			
R1015	1-249-412-11	CARBON 390 5% 1/4W	
R1016	1-249-412-11	CARBON 390 5% 1/4W	
R1017	1-249-412-11	CARBON 390 5% 1/4W	
R1018	1-249-412-11	CARBON 390 5% 1/4W	
R1038	1-249-417-11	CARBON 1K 5% 1/4W	
R1039	1-249-417-11	CARBON 1K 5% 1/4W	
R1040	1-249-417-11	CARBON 1K 5% 1/4W	
R1041	1-249-437-11	CARBON 47K 5% 1/4W	
< SWITCH >			
S1001	1-554-303-21	SWITCH, TACTILE (VIDEO 1)	
S1002	1-554-303-21	SWITCH, TACTILE (VIDEO 2)	
S1003	1-554-303-21	SWITCH, TACTILE (VIDEO 3)	
S1004	1-554-303-21	SWITCH, TACTILE (VIDEO 4)	
S1005	1-554-303-21	SWITCH, TACTILE (VIDEO 5)	
S1006	1-554-303-21	SWITCH, TACTILE (LD)	
S1007	1-554-303-21	SWITCH, TACTILE (TV)	
S1008	1-554-303-21	SWITCH, TACTILE (TAPE 1)	
S1009	1-554-303-21	SWITCH, TACTILE (TAPE 2)	
S1010	1-554-303-21	SWITCH, TACTILE (CD)	

Ref. No.	Part No.	Description	Remark
S1011	1-554-303-21	SWITCH, TACTILE (TUNER)	
S1012	1-554-303-21	SWITCH, TACTILE (PHONO)	
S1013	1-554-303-21	SWITCH, TACTILE (DISPLAY MODE)	
S1014	1-554-303-21	SWITCH, TACTILE (MIX)	
S1015	1-554-303-21	SWITCH, TACTILE (TEST TONE)	
S1016	1-554-303-21	SWITCH, TACTILE (PLO PROLOGIC MODE)	
S1017	1-554-303-21	SWITCH, TACTILE (CHARACTER)	
S1018	1-554-303-21	SWITCH, TACTILE (REC OUT SET)	
S1019	1-554-303-21	SWITCH, TACTILE (REC OUT CHECK)	
S1020	1-554-303-21	SWITCH, TACTILE (SOURCE DIRECT)	
S1021	1-554-303-21	SWITCH, TACTILE (SORROUND MODE)	

* 1-637-640-11 ENC BOARD			

< CONNECTOR >			
CND803	* 1-564-337-61	PIN, CONNECTOR 3P	
< VARIABLE RESISTOR >			
RV1001	1-466-203-11	ENCODER, ROTARY (ACOUSTIC CONTROL)	

* 1-434-130-31 F SP BOARD, COMPLETE			

< CAPACITOR >			
C013	1-136-163-00	FILM 0.068uF 5% 50V	
C014	1-136-163-00	FILM 0.068uF 5% 50V	
C050	1-136-165-00	FILM 0.1uF 5% 50V	
C051	1-124-471-00	ELECT 1000uF 20% 50V	
C613	1-136-163-00	FILM 0.068uF 5% 50V	
C614	1-136-163-00	FILM 0.068uF 5% 50V	
C663	1-136-163-00	FILM 0.068uF 5% 50V	
C664	1-136-163-00	FILM 0.068uF 5% 50V	
< CONNECTOR >			
CND804	* 1-564-498-11	PIN, CONNECTOR 5P	
CND817	* 1-564-674-11	PIN, CONNECTOR 8P	
CND818	* 1-564-243-00	PIN, CONNECTOR 6P	
CNE709	* 1-564-509-11	PLUG, CONNECTOR 6P	
CNE714	* 1-564-508-11	PLOG, CONNECTOR 5P	
< DIODE >			
D006	8-719-912-20	DIODE 1SS120	
D007	8-719-912-20	DIODE 1SS120	
D050	8-719-912-20	DIODE 1SS120	
D052	8-719-912-20	DIODE 1SS120	

F SP M VOL

Ref. No.	Part No.	Description	Remark
D054	8-719-912-20	DIODE 1SS120	
D055	8-719-912-20	DIODE 1SS120	
D056	8-719-912-20	DIODE 1SS120	
< COIL >			
L001	* 1-420-872-00	COIL, AIR CORE	
L601	* 1-420-872-00	COIL, AIR CORE	
L651	* 1-420-872-00	COIL, AIR CORE	
< TRANSISTOR >			
Q051	8-729-140-84	TRANSISTOR 2SC1841-PAFAEA	
Q052	8-729-620-05	TRANSISTOR 2SC2603-EF	
Q053	8-729-620-05	TRANSISTOR 2SC2603-EF	
Q054	8-729-620-05	TRANSISTOR 2SC2603-EF	
Q055	8-729-620-05	TRANSISTOR 2SC2603-EF	
Q056	8-729-620-05	TRANSISTOR 2SC2603-EF	
Q057	8-729-620-05	TRANSISTOR 2SC2603-EF	
< RESISTOR >			
R030	1-247-727-11	CARBON	10 5% 1/2W
R031	1-247-727-11	CARBON	10 5% 1/2W
R032	1-249-497-11	CARBON	33K 5% 1/4W
R038	1-247-749-11	CARBON	560 5% 1/2W
R050	1-259-452-11	CARBON	10K 5% 1/6W
R051	1-259-428-11	CARBON	1K 5% 1/6W
R052	1-259-466-11	CARBON	39K 5% 1/6W
R053	1-259-444-11	CARBON	4.7K 5% 1/6W
R054	1-259-444-11	CARBON	4.7K 5% 1/6W
R055	1-259-444-11	CARBON	4.7K 5% 1/6W
R056	1-259-468-11	CARBON	47K 5% 1/6W
R057	1-259-468-11	CARBON	47K 5% 1/6W
R058	1-259-468-11	CARBON	47K 5% 1/6W
R059	1-259-468-11	CARBON	47K 5% 1/6W
R060	1-249-798-11	CARBON	680 5% 1/2W
R061	1-259-468-11	CARBON	47K 5% 1/6W
R062	1-259-444-11	CARBON	4.7K 5% 1/6W
R630	1-247-727-11	CARBON	10 5% 1/2W
R631	1-247-727-11	CARBON	10 5% 1/2W
R632	1-249-465-11	CARBON	47K 5% 1/4W
R680	1-247-727-11	CARBON	10 5% 1/2W
R681	1-247-727-11	CARBON	10 5% 1/2W
R682	1-249-965-11	CARBON	56K 1% 1/4W
< RELAY >			
RY001	1-515-533-11	RELAY (MASTER VOLUME)	
RY601	1-515-356-00	RELAY	

Ref. No.	Part No.	Description	Remark
< TERMINAL >			
TM601	1-537-235-11	TERMINAL BOARD (SP) (FRON/CENTER/SPEAKER)	

* A-4341-300-A M VOL BOARD, COMPLETE *****			
< CAPACITOR >			
C280	1-126-044-11	ELECT	1uF 20% 50V
C281	1-126-045-11	ELECT	2.2uF 20% 50V
C282	1-126-044-11	ELECT	1uF 20% 50V
C283	1-126-044-11	ELECT	1uF 20% 50V
C284	1-102-973-00	CERAMIC	100PF 5% 50V
C285	1-126-044-11	ELECT	1uF 20% 50V
C286	1-126-044-11	ELECT	1uF 20% 50V
C287	1-126-045-11	ELECT	2.2uF 20% 50V
C288	1-102-973-00	CERAMIC	100PF 5% 50V
C289	1-102-973-00	CERAMIC	100PF 5% 50V
C290	1-126-045-11	ELECT	2.2uF 20% 50V
C291	1-126-044-11	ELECT	1uF 20% 50V
C292	1-126-044-11	ELECT	1uF 20% 50V
C550	1-162-282-31	CERAMIC	100PF 10% 50V
C551	1-162-282-31	CERAMIC	100PF 10% 50V
C552	1-124-994-11	ELECT	100uF 20% 10V
C553	1-164-159-11	CERAMIC	0.1uF 50V
< CONNECTOR >			
CND810	* 1-506-503-11	PIN, CONNECTOR 9P	
CNE102	* 1-564-505-11	PLUG, CONNECTOR 2P	
CNE703	* 1-564-507-11	PLUG, CONNECTOR 4P	
CNE711	* 1-564-509-11	PLUG, CONNECTOR 6P	
CNE712	* 1-564-508-11	PLUG, CONNECTOR 5P	
CNE713	* 1-564-508-11	PLUG, CONNECTOR 5P	
CNP202	* 1-564-705-11	PIN, CONNECTOR (SMALL TYPE) 3P	
CNP203	* 1-564-705-11	PIN, CONNECTOR (SMALL TYPE) 3P	
CNP214	* 1-564-705-11	PIN, CONNECTOR (SMALL TYPE) 3P	
CNP711	* 1-564-704-11	PIN, CONNECTOR (SMALL TYPE) 2P	
< DIODE >			
D550	8-719-912-20	DIODE 1SS120	
D551	8-719-912-20	DIODE 1SS120	
< IC >			
IC280	8-759-514-77	IC NE571N-A	
IC281	8-759-514-77	IC NE571N-A	
IC550	8-759-820-11	IC LC7535	

M VOL **MUT** **HP** **P SW** **REAR**

Ref. No.	Part No.	Description	Remark
IC551	8-759-945-58	IC RC4558P	
IC552	8-759-710-59	IC NJM4580D-D	
IC553	8-759-945-58	IC RC4558P	
IC555	8-759-820-11	IC LC7535	
IC556	8-759-820-62	IC LB1639	
< TRANSISTOR >			
Q550	8-729-900-80	TRANSISTOR DTC114ES	
Q551	8-729-900-80	TRANSISTOR DTC114ES	
< RESISTOR >			
R280	1-247-887-00	CARBON	220K 5% 1/4W
R281	1-249-417-11	CARBON (SMALL)	1K 5% 1/4W
R282	1-259-464-11	CARBON	33K 5% 1/6W
R283	1-259-464-11	CARBON	33K 5% 1/6W
R284	1-247-887-00	CARBON	220K 5% 1/4W
R285	1-249-417-11	CARBON (SMALL)	1K 5% 1/4W
R287	1-249-417-11	CARBON (SMALL)	1K 5% 1/4W
R288	1-247-887-00	CARBON	220K 5% 1/4W
R286	1-259-452-11	CARBON	10K 5% 1/6W
R289	1-259-452-11	CARBON	10K 5% 1/6W
R550	1-259-464-11	CARBON	33K 5% 1/6W
R551	1-259-430-11	CARBON	1.2K 5% 1/6W
R552	1-259-452-11	CARBON	10K 5% 1/6W
R553	1-259-430-11	CARBON	1.2K 5% 1/6W
R554	1-259-452-11	CARBON	10K 5% 1/6W
R555	1-259-430-11	CARBON	1.2K 5% 1/6W
R560	1-249-407-11	CARBON	150 5% 1/4W
< VARIABLE RESISTOR >			
RV550	1-241-254-12	RES, VAR CARBON 20KX5	
< RELAY >			
RY550	1-515-614-11	RELAY	

* 1-637-653-11 MUT BOARD			

< CONNECTOR >			
CND807	* 1-564-339-61	PIN, CONNECTOR 5P	
< DIODE >			
D1014	8-719-301-49	DIODE SEL2810A (MUTING)	
< SWITCH >			
S1022	1-554-303-21	SWITCH, TACTILE (MUTING)	
S1023	1-554-303-21	SWITCH, TACTILE (MODE)	

Ref. No.	Part No.	Description	Remark
* 1-637-646-11 HP BOARD			

< CONNECTOR >			
CNE710	* 1-564-508-11	PLUG, CONNECTOR 5P	
< DIODE >			
D681	8-719-912-20	DIODE 1SS120	
D682	8-719-920-20	DIODE 1SS120	
< JACK >			
J601	1-507-796-71	JACK (HEADPHONES)	
< RESISTOR >			
R682	1-247-749-11	CARBON	560 5% 1/2W
R683	1-247-749-11	CARBON	560 5% 1/2W
R689	1-249-556-11	CARBON	1.5K 5% 1/4W
< RELAY >			
RY681	1-515-727-11	RELAY	

* 1-637-638-11 P SW BOARD			

< SWITCH >			
S1024	1-554-303-21	SWITCH, TACTILE (POWER ON/STANDBY)	

* A-4341-302-A REAR BOARD, COMPLETE			

1-533-225-11 HOLDER, FUSE			
< CAPACITOR >			
C801	1-124-925-11	ELECT	2.2uF 20% 100V
C802	1-162-286-31	CERAMIC	220PF 10% 50V
C803	1-162-286-31	CERAMIC	220PF 10% 50V
C804	1-126-176-11	ELECT	220uF 20% 10V
C805	1-126-233-11	ELECT	22uF 20% 50V
C806	1-124-122-11	ELECT	100uF 20% 50V
C807	1-124-910-11	ELECT	47uF 20% 50V
C808	1-136-165-00	FILM	0.1uF 5% 50V
C809	1-136-163-00	FILM	0.068uF 5% 50V
C810	1-136-163-00	FILM	0.068uF 5% 50V

REAR **SIRCS**

Ref. No.	Part No.	Description	Remark
C851	1-124-925-11	ELECT 2.2uF	20% 100V
C852	1-162-286-31	CERAMIC 220PF	10% 50V
C853	1-162-286-31	CERAMIC 220PF	10% 50V
C854	1-126-176-11	ELECT 220uF	20% 10V
C855	1-126-233-11	ELECT 22uF	20% 50V
C856	1-126-233-11	ELECT 22uF	20% 50V
C857	1-124-910-11	ELECT 47uF	20% 50V
C858	1-136-165-00	FILM 0.1uF	5% 50V
C859	1-136-163-00	FILM 0.068uF	5% 50V
C860	1-136-163-00	FILM 0.068uF	5% 50V
C961	1-124-919-11	ELECT 220uF	20% 63V
C962	1-124-910-11	ELECT 47uF	20% 50V
C963	1-126-975-11	ELECT 4700uF	20% 42V
C964	1-126-975-11	ELECT 4700uF	20% 42V

< CONNECTOR >

- CND815 * 1-564-337-71 PIN, CONNECTOR 3P
- CNE212 * 1-564-506-11 PLUG, CONNECTOR 3P
- CNE708 * 1-564-507-11 PLUG, CONNECTOR 4P

< DIODE >

- D751 8-719-912-20 DIODE 1SS120
- D802 8-719-912-20 DIODE 1SS120
- D851 8-719-912-20 DIODE 1SS120
- D851 8-719-912-20 DIODE 1SS120
- D959 8-719-200-82 DIODE 11ES2
- D960 8-719-016-30 DIODE UZP-39B
- D961 8-719-015-06 DIODE UZP-9.1B
- D962 8-719-302-38 DIODE RBV-602-01

< IC >

- IC801 8-749-941-52 IC STK415211

< COIL >

- L801 * 1-420-872-00 COIL, AIR CORE
- L851 * 1-420-872-00 COIL, AIR CORE

< TRANSISTOR >

- Q801 8-729-140-82 TRANSISTOR 2SA988-PAFAEA
- Q851 8-729-140-82 TRANSISTOR 2SA988-PAFAEA

< RESISTOR >

- R801 1-249-438-11 CARBON 56K 5% 1/4W
- R802 1-249-417-11 CARBON 1K 5% 1/4W
- R803 1-249-414-11 CARBON 560 5% 1/4W
- R804 1-249-438-11 CARBON 56K 5% 1/4W
- R805 Δ 1-247-700-11 CARBON 100 5% 1/4W F

Ref. No.	Part No.	Description	Remark
R806	1-249-421-11	CARBON 2.2K 5%	1/4W
R807	1-247-756-11	CARBON 2.2K 5%	1/2W
R808	1-249-405-11	CARBON 100 5%	1/4W
R809	1-247-752-11	CARBON 1K 5%	1/2W
R810	1-247-752-11	CARBON 1K 5%	1/2W
R811	1-249-431-11	CARBON 15K 5%	1/4W
R812	1-249-417-11	CARBON 1K 5%	1/4W
R813	1-217-151-00	RES, METAL PLATE 0.22	
R814	1-249-438-11	CARBON 56K 5%	1/4W
R815	1-247-727-11	CARBON 10 5%	1/2W
R816	1-247-727-11	CARBON 10 5%	1/2W
R817	1-247-749-11	CARBON 560 5%	1/2W
R851	1-249-438-11	CARBON 56K 5%	1/4W
R852	1-249-417-11	CARBON 1K 5%	1/4W
R853	1-249-414-11	CARBON 560 5%	1/4W

- R854 1-249-438-11 CARBON 56K 5% 1/4W
- R856 1-249-421-11 CARBON 2.2K 5% 1/4W
- R857 1-247-756-11 CARBON 2.2K 5% 1/2W
- R861 1-249-431-11 CARBON 15K 5% 1/4W
- R862 1-249-417-11 CARBON 1K 5% 1/4W
- R863 1-217-151-00 RES, METAL PLATE 0.22
- R864 1-249-437-11 CARBON 47K 5% 1/4W
- R865 1-247-727-11 CARBON 10 5% 1/2W
- R866 1-247-727-11 CARBON 10 5% 1/2W
- R952 Δ 1-215-868-00 METAL OXIDE 680 5% 1W F
- R953 1-249-421-11 CARBON 2.2K 5% 1/4W

< RELAY >

- RY801 1-515-533-11 RELAY

< TERMINAL >

- TM801 1-537-314-11 TERMINAL BOARD (SP) (REAR SPEAKER)

- * 1-637-652-11 SIRCS BOARD
- *****

< CONNECTOR >

- CND802 * 1-564-338-00 PIN, CONNECTOR 4P

< DIODE >

- D1015 8-719-912-20 DIODE 1SS120
- D1016 8-719-912-20 DIODE 1SS120

< JACK >

- J1001 1-564-980-11 PIN, CONNECTOR 4P (CONTROL S AUDIO OUT)
- J1002 1-566-740-11 JACK (CONTROL S OUT)
- J1003 1-566-740-11 JACK (CONTROL S IN)

Note: The components identified by mark Δ or dotted line with mark Δ are critical for safety. Replace only with part number specified.

SIRCS

SP SW

SUR

Ref. No.	Part No.	Description	Remark
< TRANSISTOR >			
Q1010	8-729-900-80	TRANSISTOR DTC114ES	
Q1011	8-729-900-80	TRANSISTOR DTC114ES	
Q1012	8-729-900-61	TRANSISTOR DTA114ES	
< RESISTOR >			
R1019	1-249-421-11	CARBON 2.2K 5% 1/4W	
R1020	1-249-429-11	CARBON 10K 5% 1/4W	
R1021	1-249-393-11	CARBON 10 5% 1/4W	

* 1-637-639-11 SP SW BOARD			

< CONNECTOR >			
CND813	* 1-564-338-71	PIN. CONNECTOR 4P	
< SWITCH >			
SW601	1-572-509-11	SWITCH, PUSH (2 KEY) (SPEAKERS)	

* A-4341-301-A SUR BOARD, COMPLETE			

< CAPACITOR >			
C301	1-126-163-11	ELECT 4.7uF 20% 50V	
C302	1-164-159-11	CERAMIC 0.1uF 50V	
C303	1-164-159-11	CERAMIC 0.1uF 50V	
C304	1-130-478-00	MYLAR 0.0039uF 5% 50V	
C305	1-130-475-00	MYLAR 0.0022uF 5% 50V	
C307	1-126-163-11	ELECT 4.7uF 20% 50V	
C308	1-126-163-11	ELECT 4.7uF 20% 50V	
C309	1-126-059-11	ELECT 10uF 20% 50V	
C310	1-126-059-11	ELECT 10uF 20% 50V	
C311	1-126-049-11	ELECT 22uF 20% 25V	
C312	1-126-059-11	ELECT 10uF 20% 50V	
C313	1-130-482-00	MYLAR 0.0082uF 5% 50V	
C314	1-126-049-11	ELECT 22uF 20% 25V	
C315	1-130-476-00	MYLAR 0.0027uF 5% 50V	
C316	1-126-059-11	ELECT 10uF 20% 50V	
C317	1-126-059-11	ELECT 10uF 20% 50V	
C318	1-126-049-11	ELECT 22uF 20% 25V	
C319	1-162-211-31	CERAMIC 33PF 5% 50V	
C320	1-162-211-31	CERAMIC 33PF 5% 50V	
C323	1-130-481-00	MYLAR 0.0068uF 5% 50V	

Ref. No.	Part No.	Description	Remark
C324	1-110-342-11	MYLAR 390PF 5% 50V	
C326	1-126-044-11	ELECT 1uF 20% 50V	
C329	1-126-163-11	ELECT 4.7uF 20% 50V	
C330	1-126-163-11	ELECT 4.7uF 20% 50V	
C331	1-130-476-00	MYLAR 0.0027uF 5% 50V	
C332	1-130-476-00	MYLAR 0.0027uF 5% 50V	
C333	1-130-476-00	MYLAR 0.0027uF 5% 50V	
C334	1-130-481-00	MYLAR 0.0068uF 5% 50V	
C335	1-130-481-00	MYLAR 0.0068uF 5% 50V	
C336	1-130-481-00	MYLAR 0.0068uF 5% 50V	
C337	1-126-163-11	ELECT 4.7uF 20% 50V	
C338	1-110-342-11	MYLAR 390PF 5% 50V	
C339	1-110-342-11	MYLAR 390PF 5% 50V	
C340	1-110-342-11	MYLAR 390PF 5% 50V	
C341	1-126-059-11	ELECT 10uF 20% 50V	
C342	1-126-023-11	ELECT 100uF 20% 25V	
C343	1-136-153-00	FILM 0.01uF 5% 50V	
C344	1-126-059-11	ELECT 10uF 20% 50V	
C345	1-126-059-11	ELECT 10uF 20% 50V	
C347	1-126-059-11	ELECT 10uF 20% 50V	
C348	1-136-153-00	FILM 0.01uF 5% 50V	
C349	1-136-153-00	FILM 0.01uF 5% 50V	
C352	1-126-163-11	ELECT 4.7uF 20% 50V	
C353	1-130-475-00	MYLAR 0.0022uF 5% 50V	
C354	1-136-165-00	FILM 0.1uF 5% 50V	
C355	1-136-165-00	FILM 0.1uF 5% 50V	
C357	1-136-165-00	FILM 0.1uF 5% 50V	
C359	1-130-469-00	MYLAR 680PF 5% 50V	
C360	1-136-167-00	FILM 0.15uF 5% 50V	
C361	1-136-171-00	FILM 0.33uF 5% 50V	
C362	1-130-469-00	MYLAR 680PF 5% 50V	
C364	1-136-167-00	FILM 0.15uF 5% 50V	
C365	1-136-171-00	FILM 0.33uF 5% 50V	
C366	1-126-059-11	ELECT 10uF 20% 50V	
C367	1-136-169-00	FILM 0.22uF 5% 50V	
C368	1-126-163-11	ELECT 4.7uF 20% 50V	
C369	1-126-163-11	ELECT 4.7uF 20% 50V	
C371	1-136-169-00	FILM 0.22uF 5% 50V	
C372	1-126-163-11	ELECT 4.7uF 20% 50V	
C373	1-126-163-11	ELECT 4.7uF 20% 50V	
C374	1-130-481-00	MYLAR 0.0068uF 5% 50V	
C375	1-130-481-00	MYLAR 0.0068uF 5% 50V	
C376	1-126-023-11	ELECT 100uF 20% 25V	
C377	1-126-022-11	ELECT 47uF 20% 16V	
C378	1-136-169-00	FILM 0.22uF 5% 50V	
C379	1-126-044-11	ELECT 1uF 20% 50V	
C380	1-136-169-00	FILM 0.22uF 5% 50V	
C381	1-126-163-11	ELECT 4.7uF 20% 50V	
C382	1-126-163-11	ELECT 4.7uF 20% 50V	

SUR

Ref. No.	Part No.	Description			Remark
C383	1-136-169-00	FILM	0.22uF	5%	50V
C384	1-136-158-00	FILM	0.027uF	5%	50V
C385	1-130-479-00	MYLAR	0.0047uF	5%	50V
C386	1-136-169-00	FILM	0.22uF	5%	50V
C387	1-126-022-11	ELECT	47uF	20%	16V
C388	1-136-159-00	FILM	0.033uF	5%	50V
C389	1-126-059-11	ELECT	10uF	20%	50V
C390	1-136-171-00	FILM	0.33uF	5%	50V
C391	1-126-023-11	ELECT	100uF	20%	25V
C392	1-136-165-00	FILM	0.1uF	5%	50V
C393	1-136-173-00	FILM	0.47uF	5%	50V
C394	1-126-049-11	ELECT	22uF	20%	25V
C395	1-126-059-11	ELECT	10uF	20%	50V
C396	1-126-023-11	ELECT	100uF	20%	25V
C398	1-126-044-11	ELECT	1uF	20%	50V
C399	1-126-044-11	ELECT	1uF	20%	50V
C1001	1-125-548-11	CAP. DOUBLE LAYERS	0.1F		
C1002	1-124-994-11	ELECT	100uF	20%	10V
C1003	1-161-379-00	CERAMIC	0.01uF	20%	25V
C1004	1-161-379-00	CERAMIC	0.01uF	20%	25V
C1005	1-126-059-11	ELECT	10uF	20%	50V
C1101	1-126-044-11	ELECT	1uF	20%	50V
C1110	1-161-379-00	CERAMIC	0.01uF	20%	50V
< CONNECTOR >					
CND801 *	1-564-337-00	PIN, CONNECTOR	3P		
CND802 *	1-564-338-00	PIN, CONNECTOR	4P		
CND803 *	1-564-337-61	PIN, CONNECTOR	3P		
CND804 *	1-564-339-00	PIN, CONNECTOR	5P		
CND805 *	1-564-338-61	PIN, CONNECTOR	4P		
CND806 *	1-564-340-61	PIN, CONNECTOR	6P		
CND808 *	1-564-342-61	PIN, CONNECTOR	8P		
CND809 *	1-564-340-00	PIN, CONNECTOR	6P		
CND810 *	1-564-337-71	PIN, CONNECTOR	3P		
CND811 *	1-506-503-11	PIN, CONNECTOR	9P		
CND812 *	1-564-339-61	PIN, CONNECTOR	5P		
CNE102 *	1-564-505-11	PLUG, CONNECTOR	2P		
CNE201 *	1-564-506-11	PLUG, CONNECTOR	3P		
CNE705 *	1-564-507-11	PLUG, CONNECTOR	4P		
CNE707 *	1-564-507-11	PLUG, CONNECTOR	4P		
CNP202 *	1-564-705-11	PIN, CONNECTOR (SMALL TYPE)	3P		
CNP203 *	1-564-705-11	PIN, CONNECTOR (SMALL TYPE)	3P		
< DIODE >					
D301	8-719-912-20	DIODE 1SS120			
D302	8-719-912-20	DIODE 1SS120			
D303	8-719-912-20	DIODE 1SS120			
D304	8-719-912-20	DIODE 1SS120			
D1001	8-719-912-20	DIODE 1SS120			

Ref. No.	Part No.	Description		Remark
D1002	8-719-912-20	DIODE 1SS120		
D1003	8-719-912-20	DIODE 1SS120		
D1004	8-719-912-20	DIODE 1SS120		
D1006	8-719-912-20	DIODE 1SS120		
D1017	8-719-912-20	DIODE 1SS120		
D1018	8-719-912-20	DIODE 1SS120		
D1019	8-719-912-20	DIODE 1SS120		
< IC >				
IC301	8-759-503-59	IC YM7128		
IC302	8-759-000-48	IC MC14052BCP		
IC304	8-759-823-26	IC LA2775K		
IC305	8-759-823-27	IC LA2770K		
IC306	8-759-823-25	IC LA2730K		
IC307	8-759-801-01	IC LC4966		
IC308	8-759-801-01	IC LC4966		
IC309	8-759-801-01	IC LC4966		
IC310	8-759-604-70	IC M51523AL		
IC311	8-759-945-58	IC RC4558P		
IC312	8-759-945-58	IC RC4558P		
IC313	8-759-945-58	IC RC4558P		
IC314	8-759-990-82	IC TL082CP		
IC315	8-759-945-58	IC RC4558P		
IC316	8-759-945-58	IC RC4558P		
IC317	8-759-113-12	IC uPC4084C		
IC318	8-759-945-58	IC RC4558P		
IC1001	8-759-637-01	IC M50747-F80SP		
< COIL >				
L301	1-410-971-11	INDUCTOR	10uH	
< TRANSISTOR >				
Q301	8-729-900-80	TRANSISTOR DTC114ES		
Q302	8-729-900-80	TRANSISTOR DTC114ES		
Q303	8-729-900-80	TRANSISTOR DTC114ES		
Q304	8-729-224-62	TRANSISTOR 2SK246GR		
Q305	8-729-900-80	TRANSISTOR DTC114ES		
Q306	8-729-900-89	TRANSISTOR DTC144ES		
Q307	8-729-900-89	TRANSISTOR DTC144ES		
Q308	8-729-900-89	TRANSISTOR DTC144ES		
Q309	8-729-900-65	TRANSISTOR DTA144ES		
Q310	8-729-900-89	TRANSISTOR DTC144ES		
Q311	8-729-900-89	TRANSISTOR DTC144ES		
Q312	8-729-900-65	TRANSISTOR DTA144ES		
Q313	8-729-900-89	TRANSISTOR DTC144ES		
Q314	8-729-900-65	TRANSISTOR DTA144ES		
Q315	8-729-900-89	TRANSISTOR DTC144ES		

SUR

Ref. No.	Part No.	Description	Remark	Ref. No.	Part No.	Description	Remark
Q316	8-729-900-80	TRANSISTOR DTC114ES		R340	1-249-428-11	CARBON	8. 2K 5% 1/4W
Q317	8-729-900-80	TRANSISTOR DTC114ES		R341	1-249-428-11	CARBON	8. 2K 5% 1/4W
Q318	8-729-900-80	TRANSISTOR DTC114ES		R342	1-249-428-11	CARBON	8. 2K 5% 1/4W
Q1001	8-729-620-05	TRANSISTOR 2SC2603-EF		R343	1-249-428-11	CARBON	8. 2K 5% 1/4W
Q1013	8-729-900-61	TRANSISTOR DTA114ES		R344	1-249-428-11	CARBON	8. 2K 5% 1/4W
< RESISTOR >				R345	1-249-428-11	CARBON	8. 2K 5% 1/4W
R300	1-249-431-11	CARBON	15K 5% 1/4W	R346	1-249-433-11	CARBON	22K 5% 1/4W
R301	1-249-426-11	CARBON	5. 6K 5% 1/4W	R347	1-249-433-11	CARBON	22K 5% 1/4W
R302	1-249-429-11	CARBON	10K 5% 1/4W	R348	1-249-433-11	CARBON	22K 5% 1/4W
R303	1-249-429-11	CARBON	10K 5% 1/4W	R349	1-249-435-11	CARBON	33K 5% 1/4W
R304	1-249-429-11	CARBON	10K 5% 1/4W	R350	1-249-437-11	CARBON	47K 5% 1/4W
R305	1-249-429-11	CARBON	10K 5% 1/4W	R351	1-249-437-11	CARBON	47K 5% 1/4W
R306	1-249-429-11	CARBON	10K 5% 1/4W	R352	1-249-435-11	CARBON	33K 5% 1/4W
R307	1-249-432-11	CARBON	18K 5% 1/4W	R353	1-249-431-11	CARBON	15K 5% 1/4W
R308	1-249-429-11	CARBON	10K 5% 1/4W	R354	1-247-852-11	CARBON	7. 5K 5% 1/4W
R309	1-249-431-11	CARBON	15K 5% 1/4W	R355	1-247-852-11	CARBON	7. 5K 5% 1/4W
R310	1-249-437-11	CARBON	47K 5% 1/4W	R356	1-249-433-11	CARBON	22K 5% 1/4W
R311	1-249-429-11	CARBON	10K 5% 1/4W	R357	1-249-433-11	CARBON	22K 5% 1/4W
R312	1-249-429-11	CARBON	10K 5% 1/4W	R358	1-249-429-11	CARBON	10K 5% 1/4W
R313	1-249-430-11	CARBON	12K 5% 1/4W	R359	1-249-423-11	CARBON	3. 3K 5% 1/4W
R314	1-249-430-11	CARBON	12K 5% 1/4W	R360	1-249-423-11	CARBON	3. 3K 5% 1/4W
R315	1-249-429-11	CARBON	10K 5% 1/4W	R361	1-249-435-11	CARBON	33K 5% 1/4W
R316	1-249-429-11	CARBON	10K 5% 1/4W	R362	1-249-421-11	CARBON	2. 2K 5% 1/4W
R317	1-249-433-11	CARBON	22K 5% 1/4W	R363	1-249-421-11	CARBON	2. 2K 5% 1/4W
R318	1-249-437-11	CARBON	47K 5% 1/4W	R364	1-249-421-11	CARBON	2. 2K 5% 1/4W
R319	1-249-433-11	CARBON	22K 5% 1/4W	R365	1-249-433-11	CARBON	22K 5% 1/4W
R320	1-249-429-11	CARBON	10K 5% 1/4W	R366	1-249-429-11	CARBON	10K 5% 1/4W
R321	1-249-437-11	CARBON	47K 5% 1/4W	R367	1-249-408-11	CARBON	180 5% 1/4W
R322	1-247-903-00	CARBON	1M 5% 1/4W	R368	1-249-423-11	CARBON	3. 3K 5% 1/4W
R323	1-249-434-11	CARBON	27K 5% 1/4W	R369	1-249-437-11	CARBON	47K 5% 1/4W
R324	1-249-431-11	CARBON	15K 5% 1/4W	R370	1-247-889-00	CARBON	270K 5% 1/4W
R325	1-249-428-11	CARBON	8. 2K 5% 1/4W	R371	1-247-850-11	CARBON	6. 2K 5% 1/4W
R326	1-249-441-11	CARBON	100K 5% 1/4W	R373	1-247-889-00	CARBON	270K 5% 1/4W
R327	1-249-429-11	CARBON	10K 5% 1/4W	R375	1-249-435-11	CARBON	33K 5% 1/4W
R328	1-249-437-11	CARBON	47K 5% 1/4W	R376	1-249-430-11	CARBON	12K 5% 1/4W
R329	1-249-441-11	CARBON	100K 5% 1/4W	R377	1-249-433-11	CARBON	22K 5% 1/4W
R330	1-249-428-11	CARBON	8. 2K 5% 1/4W	R378	1-249-433-11	CARBON	22K 5% 1/4W
R331	1-249-435-11	CARBON	33K 5% 1/4W	R379	1-249-441-11	CARBON	100K 5% 1/4W
R332	1-249-435-11	CARBON	33K 5% 1/4W	R380	1-249-437-11	CARBON	47K 5% 1/4W
R333	1-259-884-11	CARBON	4. 7M 5% 1/4W	R381	1-249-423-11	CARBON	3. 3K 5% 1/4W
R334	1-259-884-11	CARBON	4. 7M 5% 1/4W	R382	1-249-417-11	CARBON	1K 5% 1/4W
R335	1-249-433-11	CARBON	22K 5% 1/4W	R383	1-249-417-11	CARBON	1K 5% 1/4W
R336	1-249-433-11	CARBON	22K 5% 1/4W	R384	1-249-417-11	CARBON	1K 5% 1/4W
R337	1-249-428-11	CARBON	8. 2K 5% 1/4W	R385	1-249-421-11	CARBON	2. 2K 5% 1/4W
R338	1-249-428-11	CARBON	8. 2K 5% 1/4W	R386	1-249-417-11	CARBON	1K 5% 1/4W
R339	1-249-428-11	CARBON	8. 2K 5% 1/4W	R387	1-249-441-11	CARBON	100K 5% 1/4W
				R388	1-249-429-11	CARBON	10K 5% 1/4W
				R389	1-249-441-11	CARBON	100K 5% 1/4W
				R391	1-247-895-00	CARBON	470K 5% 1/4W

SUR TONE

Ref. No.	Part No.	Description	Remark		
R392	1-249-429-11	CARBON	10K	5%	1/4W
R393	1-249-434-11	CARBON	27K	5%	1/4W
R394	1-249-431-11	CARBON	15K	5%	1/4W
R396	1-249-421-11	CARBON	2.2K	5%	1/4W
R397	1-249-421-11	CARBON	2.2K	5%	1/4W
R398	1-249-421-11	CARBON	2.2K	5%	1/4W
R399	1-249-421-11	CARBON	2.2K	5%	1/4W
R1003	1-249-437-11	CARBON	47K	5%	1/4W
R1004	1-249-437-11	CARBON	47K	5%	1/4W
R1005	1-249-437-11	CARBON	47K	5%	1/4W
R1006	1-249-437-11	CARBON	47K	5%	1/4W
R1007	1-249-437-11	CARBON	47K	5%	1/4W
R1008	1-249-437-11	CARBON	47K	5%	1/4W
R1009	1-249-437-11	CARBON	47K	5%	1/4W
R1010	1-247-903-00	CARBON	1M	5%	1/4W
R1011	1-247-895-00	CARBON	470K	5%	1/4W
R1012	1-249-433-11	CARBON	22K	5%	1/4W
R1013	1-249-429-11	CARBON	10K	5%	1/4W
R1014	1-249-401-11	CARBON	47	5%	1/4W
R1022	1-249-437-11	CARBON	47K	5%	1/4W
R1023	1-249-437-11	CARBON	47K	5%	1/4W
R1024	1-249-437-11	CARBON	47K	5%	1/4W
R1025	1-249-437-11	CARBON	47K	5%	1/4W
R1026	1-249-437-11	CARBON	47K	5%	1/4W
R1027	1-247-895-00	CARBON	470K	5%	1/4W
R1028	1-247-895-00	CARBON	470K	5%	1/4W
R1030	1-249-441-11	CARBON	100K	5%	1/4W
R1031	1-249-425-11	CARBON	4.7K	5%	1/4W
R1033	1-249-437-11	CARBON	47K	5%	1/4W
R1034	1-249-437-11	CARBON	47K	5%	1/4W
R1035	1-249-417-11	CARBON	1K	5%	1/4W
R1036	1-249-417-11	CARBON	1K	5%	1/4W
R1037	1-249-405-11	CARBON	100	5%	1/4W
R1038	1-249-429-11	CARBON	10K	5%	1/4W
R1039	1-249-429-11	CARBON	10K	5%	1/4W
R1043	1-249-417-11	CARBON	1K	5%	1/4W

< VARIABLE RESISTOR >

RV301	1-238-603-11	RES. ADJ. CARBON 100K (AUTO INPUT BALANCE)
RV302	1-238-600-11	RES. ADJ. CARBON 10K (AUTO INPUT BALANCE)

< CERAMIC >

X301	1-579-124-11	VIBRATOR, CERAMIC (7.70MHz)
X1001	1-577-157-11	VIBRATOR, CERAMIC (8.00MHz)

* A-4341-297-A TONE BOARD, COMPLETE

Ref. No.	Part No.	Description	Remark		
< CAPACITOR >					
C203	1-126-163-11	ELECT	4.7uF	20%	50V
C204	1-126-022-11	ELECT	47uF	20%	16V
C205	1-162-211-31	CERAMIC	33PF	5%	50V
C206	1-126-163-11	ELECT	4.7uF	20%	50V
C207	1-130-481-00	MYLAR	0.0068uF	5%	50V
C208	1-136-163-00	FILM	0.068uF	5%	50V
C209	1-130-477-00	MYLAR	0.0033uF	5%	50V
C210	1-136-159-00	FILM	0.033uF	5%	50V
C253	1-126-163-11	ELECT	4.7uF	20%	50V
C254	1-126-022-11	ELECT	47uF	20%	16V
C255	1-162-211-31	CERAMIC	33PF	5%	50V
C256	1-126-163-11	ELECT	4.7uF	20%	50V
C257	1-130-481-00	MYLAR	0.0068uF	5%	50V
C258	1-136-163-00	FILM	0.068uF	5%	50V
C259	1-130-477-00	MYLAR	0.0033uF	5%	50V
C260	1-136-159-00	FILM	0.033uF	5%	50V
C402	1-126-022-11	ELECT	47uF	20%	16V
C404	1-126-022-11	ELECT	47uF	20%	16V
C405	1-162-211-31	CERAMIC	33PF	5%	50V
C406	1-126-163-11	ELECT	4.7uF	20%	50V
C407	1-130-481-00	MYLAR	0.0068uF	5%	50V
C408	1-136-163-00	FILM	0.068uF	5%	50V
C409	1-130-477-00	MYLAR	0.0033uF	5%	50V
C410	1-136-159-00	FILM	0.033uF	5%	50V
C452	1-126-022-11	ELECT	47uF	20%	16V
C454	1-126-022-11	ELECT	47uF	20%	16V
C455	1-162-211-31	CERAMIC	33PF	5%	50V
C456	1-126-163-11	ELECT	4.7uF	20%	50V
C457	1-130-481-00	MYLAR	0.0068uF	5%	50V
C458	1-136-163-00	FILM	0.068uF	5%	50V
C459	1-130-477-00	MYLAR	0.0033uF	5%	50V
C460	1-136-159-00	FILM	0.033uF	5%	50V
C504	1-126-023-11	ELECT	100uF	20%	25V
C505	1-126-022-11	ELECT	47uF	20%	25V
C506	1-110-335-11	MYLAR	100PF	5%	50V
C507	1-126-023-11	ELECT	100uF	20%	25V
C508	1-126-163-11	ELECT	4.7uF	20%	50V
C509	1-136-164-00	FILM	0.082uF	5%	50V
C511	1-136-159-00	FILM	0.033uF	5%	50V
C513	1-136-165-00	FILM	0.1uF	5%	50V
C514	1-136-153-00	FILM	0.01uF	5%	50V
C515	1-110-335-11	MYLAR	100PF	5%	50V

< CONNECTOR >

CNE110	* 1-564-505-11	PLUG, CONNECTOR 2P
CNE111	* 1-564-505-11	PLUG, CONNECTOR 2P
CNE210	* 1-564-506-11	PLUG, CONNECTOR 3P

tone VIDEO

Ref. No.	Part No.	Description	Remark
CNE211 *	1-564-506-11	PLUG, CONNECTOR 3P	
CNE212 *	1-564-506-11	PLUG, CONNECTOR 3P	
CNE213 *	1-564-506-11	PLUG, CONNECTOR 3P	
< IC >			
IC202	8-759-945-58	IC RC4558P	
IC402	8-759-945-58	IC RC4558P	
IC501	8-759-945-58	IC RC4558P	
< RESISTOR >			
R201	1-247-887-00	CARBON 220K 5% 1/4W	
R202	1-249-430-11	CARBON 12K 5% 1/4W	
R203	1-247-887-00	CARBON 220K 5% 1/4W	
R204	1-249-434-11	CARBON 27K 5% 1/4W	
R205	1-249-422-11	CARBON 2.7K 5% 1/4W	
R207	1-249-426-11	CARBON 5.6K 5% 1/4W	
R208	1-249-414-11	CARBON 560 5% 1/4W	
R251	1-247-887-00	CARBON 220K 5% 1/4W	
R252	1-249-430-11	CARBON 12K 5% 1/4W	
R253	1-247-887-00	CARBON 220K 5% 1/4W	
R254	1-249-434-11	CARBON 27K 5% 1/4W	
R255	1-249-422-11	CARBON 2.7K 5% 1/4W	
R257	1-249-426-11	CARBON 5.6K 5% 1/4W	
R258	1-249-414-11	CARBON 560 5% 1/4W	
R401	1-247-887-00	CARBON 220K 5% 1/4W	
R402	1-249-430-11	CARBON 12K 5% 1/4W	
R403	1-247-887-00	CARBON 220K 5% 1/4W	
R404	1-249-434-11	CARBON 27K 5% 1/4W	
R405	1-249-422-11	CARBON 2.7K 5% 1/4W	
R407	1-249-426-11	CARBON 5.6K 5% 1/4W	
R408	1-249-414-11	CARBON 560 5% 1/4W	
R451	1-247-887-00	CARBON 220K 5% 1/4W	
R452	1-249-430-11	CARBON 12K 5% 1/4W	
R453	1-247-887-00	CARBON 220K 5% 1/4W	
R454	1-249-434-11	CARBON 27K 5% 1/4W	
R455	1-249-422-11	CARBON 2.7K 5% 1/4W	
R457	1-249-426-11	CARBON 5.6K 5% 1/4W	
R458	1-249-414-11	CARBON 560 5% 1/4W	
R504	1-247-887-00	CARBON 220K 5% 1/4W	
R505	1-249-421-11	CARBON 2.2K 5% 1/4W	
R506	1-247-889-00	CARBON 270K 5% 1/4W	
R507	1-249-418-11	CARBON 1.2K 5% 1/4W	
R508	1-249-441-11	CARBON 100K 5% 1/4W	
R509	1-249-423-11	CARBON 3.3K 5% 1/4W	
R510	1-249-422-11	CARBON 2.7K 5% 1/4W	
R512	1-249-410-11	CARBON 270 5% 1/4W	
R514	1-247-832-11	CARBON 1.1K 5% 1/4W	
R519	1-249-433-11	CARBON 22K 5% 1/4W	

Ref. No.	Part No.	Description	Remark
< VARIABLE RESISTOR >			
RV202	1-237-885-11	RES. VAR. CARBON 100K/100K (REAR BASS)	
RV203	1-237-885-11	RES. VAR. CARBON 100K/100K (REAR TREBLE)	
RV402	1-237-885-11	RES. VAR. CARBON 100K/100K (FRONT BASS)	
RV403	1-237-885-11	RES. VAR. CARBON 100K/100K (FRONT TREBLE)	
RV404	1-237-886-11	RES. VAR. CARBON 100K/100K (BARANCE)	
RV501	1-241-252-11	RES. VAR. CARBON 20K/20K (CENTER BASS)	
RV502	1-241-253-11	RES. VAR. CARBON 20K/20K (CENTER MID)	
RV503	1-241-253-11	RES. VAR. CARBON 20K/20K (CENTER TREBLE)	

* A-4341-298-A VIDEO BOARD, COMPLETE			

< CAPACITOR >			
C701	1-124-471-00	ELECT 1000uF 20% 6.3V	
C702	1-124-471-00	ELECT 1000uF 20% 6.3V	
C703	1-124-471-00	ELECT 1000uF 20% 6.3V	
C704	1-124-471-00	ELECT 1000uF 20% 6.3V	
C709	1-124-907-11	ELECT 10uF 20% 50V	
C710	1-124-907-11	ELECT 10uF 20% 50V	
C711	1-161-379-00	CERAMIC 0.01uF 20% 25V	
C712	1-161-379-00	CERAMIC 0.01uF 20% 25V	
C713	1-161-379-00	CERAMIC 0.01uF 20% 25V	
C714	1-136-165-00	FILM 0.1uF 5% 50V	
C715	1-136-165-00	FILM 0.1uF 5% 50V	
C716	1-136-165-00	FILM 0.1uF 5% 50V	
C717	1-124-471-00	ELECT 1000uF 20% 6.3V	
C718	1-124-471-00	ELECT 1000uF 20% 6.3V	
C719	1-124-471-00	ELECT 1000uF 20% 6.3V	
C720	1-124-907-11	ELECT 10uF 20% 50V	
C721	1-124-907-11	ELECT 10uF 20% 50V	
C724	1-136-165-00	FILM 0.1uF 5% 50V	
C725	1-124-907-11	ELECT 10uF 20% 50V	
C726	1-124-907-11	ELECT 10uF 20% 50V	
C727	1-161-379-00	CERAMIC 0.01uF 20% 25V	
C728	1-161-379-00	CERAMIC 0.01uF 20% 25V	
C730	1-126-101-11	ELECT 100uF 20% 16V	
C731	1-126-101-11	ELECT 100uF 20% 16V	
C732	1-126-101-11	ELECT 100uF 20% 16V	
C733	1-126-101-11	ELECT 100uF 20% 16V	
C734	1-124-907-11	ELECT 10uF 20% 50V	
C736	1-126-101-11	ELECT 100uF 20% 16V	
C740	1-126-101-11	ELECT 100uF 20% 16V	
C795	1-124-925-11	ELECT 2.2uF 20% 100V	

VIDEO

Ref. No.	Part No.	Description	Remark	Ref. No.	Part No.	Description	Remark
< CONNECTOR >				< COIL >			
CND809 *	1-564-340-00	PIN, CONNECTOR 6P		L701	1-410-977-11	INDUCTOR 100uH	
CND816 *	1-564-339-71	PIN, CONNECTOR 5P		L702	1-410-977-11	INDUCTOR 100uH	
CNE105	1-564-505-11	PLUG, CONNECTOR 2P		L703	1-410-977-11	INDUCTOR 100uH	
CNE706	1-664-506-11	PLUG, CONNECTOR 3P		L704	1-410-977-11	INDUCTOR 100uH	
< DIODE >				< TRANSISTOR >			
D701	8-719-912-20	DIODE 1SS120		Q703	8-729-119-76	TRANSISTOR 2SA1175-HFE	
D702	8-719-912-20	DIODE 1SS120		Q704	8-729-119-76	TRANSISTOR 2SA1175-HFE	
D703	8-719-912-20	DIODE 1SS120		Q705	8-729-119-76	TRANSISTOR 2SA1175-HFE	
< IC >				Q706	8-729-900-74	TRANSISTOR DTC143TS	
IC701	8-759-805-14	IC LC7822		Q707	8-729-900-74	TRANSISTOR DTC143TS	
IC702	8-759-805-14	IC LC7822		Q708	8-729-900-74	TRANSISTOR DTC143TS	
IC703	8-759-030-67	IC MC14576AP		Q709	8-729-119-76	TRANSISTOR 2SA1175-HFE	
IC704	8-759-805-15	IC LC7823		Q710	8-729-119-76	TRANSISTOR 2SA1175-HFE	
IC705	8-759-805-15	IC LC7823		Q711	8-729-119-76	TRANSISTOR 2SA1175-HFE	
IC706	8-759-030-67	IC MC14576AP		Q712	8-729-119-76	TRANSISTOR 2SA1175-HFE	
IC707	8-759-030-67	IC MC14576AP		Q713	8-729-620-05	TRANSISTOR 2SC2603-EF	
< JACK >				Q715	8-729-620-05	TRANSISTOR 2SC2603-EF	
J701	1-565-319-91	JACK, PIN 2P (VIDEO 1/MONITOR VIDEO IN/OUT)		< RESISTOR >			
J702	1-565-319-91	JACK, PIN 2P (VIDEO 1/VIDEO 2 VIDEO IN/OUT)		R701	1-249-403-11	CARBON 68 5% 1/4W	
J703	1-565-319-91	JACK, PIN 2P (VIDDE 2/VIDEO 3 VIDEO IN/OUT)		R702	1-247-804-11	CARBON 75 5% 1/4W	
J704	1-565-319-91	JACK, PIN 2P (VIDEO 3/VIDEO 4 VIDEO IN/OUT)		R703	1-247-804-11	CARBON 75 5% 1/4W	
J705	1-565-319-91	JACK, PIN 2P (TV/LD VIDEO IN)		R704	1-247-804-11	CARBON 75 5% 1/4W	
J706	1-566-846-21	CONNECTOR, (S) TERMINAL 4P (MONITOR S VIDEO OUT)		R705	1-247-804-11	CARBON 75 5% 1/4W	
J707	1-566-846-21	CONNECTOR, (S) TERMINAL 4P (VIDEO 1 S VIDEO OUT)		R706	1-247-804-11	CARBON 75 5% 1/4W	
J708	1-566-846-21	CONNECTOR, (S) TERMINAL 4P (VIDEO 1 S VIDEO OUT)		R707	1-247-804-11	CARBON 75 5% 1/4W	
J709	1-566-846-21	CONNECTOR, (S) TERMINAL 4P (VIDEO 2 S VIDEO 2 IN)		R708	1-247-804-11	CARBON 75 5% 1/4W	
J710	1-566-846-21	CONNECTOR, (S) TERMINAL 4P (VIDEO 2 S VIDEO IN)		R709	1-249-403-11	CARBON 68 5% 1/4W	
J711	1-566-846-21	CONNECTOR, (S) TERMINAL 4P (VIDEO 4 S VIDEO OUT)		R710	1-249-403-11	CARBON 68 5% 1/4W	
J712	1-566-846-21	CONNECTOR, (S) TERMINAL 4P (LD S VIDEO IN)		R711	1-249-403-11	CARBON 68 5% 1/4W	
				R713	1-249-429-11	CARBON 10K 5% 1/4W	
				R714	1-249-429-11	CARBON 10K 5% 1/4W	
				R715	1-249-429-11	CARBON 10K 5% 1/4W	
				R717	1-249-429-11	CARBON 10K 5% 1/4W	
				R720	1-249-413-11	CARBON 470 5% 1/4W	
				R721	1-249-413-11	CARBON 470 5% 1/4W	
				R722	1-249-413-11	CARBON 470 5% 1/4W	
				R727	1-249-421-11	CARBON 2.2K 5% 1/4W	
				R729	1-249-421-11	CARBON 2.2K 5% 1/4W	
				R731	1-249-421-11	CARBON 2.2K 5% 1/4W	
				R733	1-249-428-11	CARBON 8.2K 5% 1/4W	
				R735	1-249-403-11	CARBON 68 5% 1/4W	
				R736	1-249-403-11	CARBON 68 5% 1/4W	
				R737	1-249-403-11	CARBON 68 5% 1/4W	

VIDEO

VIDEO 5

VOL LED

Ref. No.	Part No.	Description	Remark
R738	1-249-403-11	CARBON 68 5% 1/4W	
R739	1-249-403-11	CARBON 68 5% 1/4W	
R740	1-249-403-11	CARBON 68 5% 1/4W	
R741	1-247-804-11	CARBON 75 5% 1/4W	
R742	1-247-804-11	CARBON 75 5% 1/4W	
R743	1-247-804-11	CARBON 75 5% 1/4W	
R744	1-247-804-11	CARBON 75 5% 1/4W	
R745	1-247-804-11	CARBON 75 5% 1/4W	
R746	1-247-804-11	CARBON 75 5% 1/4W	
R747	1-247-804-11	CARBON 75 5% 1/4W	
R748	1-247-804-11	CARBON 75 5% 1/4W	
R749	1-247-804-11	CARBON 75 5% 1/4W	
R750	1-247-804-11	CARBON 75 5% 1/4W	
R751	1-249-429-11	CARBON 10K 5% 1/4W	
R752	1-249-429-11	CARBON 10K 5% 1/4W	
R753	1-249-429-11	CARBON 10K 5% 1/4W	
R754	1-249-429-11	CARBON 10K 5% 1/4W	
R755	1-249-429-11	CARBON 10K 5% 1/4W	
R756	1-249-429-11	CARBON 10K 5% 1/4W	
R757	1-249-413-11	CARBON 470 5% 1/4W	
R758	1-249-413-11	CARBON 470 5% 1/4W	
R759	1-249-413-11	CARBON 470 5% 1/4W	
R760	1-249-413-11	CARBON 470 5% 1/4W	
R763	1-249-405-11	CARBON 100 5% 1/4W	
R765	1-249-405-11	CARBON 100 5% 1/4W	
R767	1-249-405-11	CARBON 100 5% 1/4W	
R769	1-249-405-11	CARBON 100 5% 1/4W	
R772	1-249-422-11	CARBON 2.7K 5% 1/4W	
R773	1-249-441-11	CARBON 100K 5% 1/4W	
R774	1-249-441-11	CARBON 100K 5% 1/4W	
R775	1-249-441-11	CARBON 100K 5% 1/4W	
R776	1-249-428-11	CARBON 8.2K 5% 1/4W	
R777	1-249-425-11	CARBON 4.7K 5% 1/4W	
R778	1-249-422-11	CARBON 2.7K 5% 1/4W	
R780	1-249-439-11	CARBON 68K 5% 1/4W	
R781	1-247-887-00	CARBON 220K 5% 1/4W	
R782	1-247-887-00	CARBON 220K 5% 1/4W	
R783	1-247-887-00	CARBON 220K 5% 1/4W	
R784	1-247-895-00	CARBON 470K 5% 1/4W	
R785	1-247-895-00	CARBON 470K 5% 1/4W	
R786	1-247-700-11	CARBON 100 5% 1/4W	
R787	1-249-429-11	CARBON 10K 5% 1/4W	
R788	1-249-429-11	CARBON 10K 5% 1/4W	

Ref. No.	Part No.	Description	Remark
* 1-637-647-11	VIDEO 5 BOARD	*****	
< CONNECTOR >			
CNE101 * 1-564-520-11	PLUG, CONNECTOR 5P		
CNE103 * 1-564-518-11	PLUG, CONNECTOR 3P		
< JACK >			
J501 1-537-115-31	TERMINAL BOARD (VIDEO/INPUT)		
< RESISTOR >			
R147 1-249-417-11	CARBON 1K 5% 1/4W		
R197 1-249-417-11	CARBON 1K 5% 1/4W		

* 1-637-645-11	VOL LED BOARD	*****	
< DIODE >			
D552 8-719-301-44	DIODE SEL2410E-D (MASTER VOLUME)		

MISCELLANEOUS		*****	
68 Δ 1-559-297-31	CORD, POWER (AV650G)		
68 Δ 1-559-479-11	CORD, POWER (AV650)		
85 Δ 1-569-007-11	ADAPTER, CONVERSION 2P		
F901 Δ 1-532-350-00	FUSE, TIME-LAG (4A) (AV650G)		
F901 Δ 1-532-749-11	FUSE, GLASS TUBE (8A) (AV650)		
F902 Δ 1-532-746-11	FUSE, GLASS TUBE (4A) (AV650G)		
F902 Δ 1-532-746-11	FUSE, GLASS TUBE (4A) (AV650)		
F903 Δ 1-532-746-11	FUSE, GLASS TUBE (4A) (AV650G)		
F903 Δ 1-532-746-11	FUSE, GLASS TUBE (4A) (AV650)		
T901 Δ 1-448-517-21	TRANSFORMER, POWER (AV650)		
T902 Δ 1-450-509-11	TRANSFORMER, POWER (AV650G)		
T902 Δ 1-450-561-11	TRANSFORMER, POWER (AV650)		

ACCESSORY & PACKING MATERIAL		*****	
1-465-570-11	REMOTE COMMANDAR (RM-P650)		
3-752-622-21	MANUAL, INSTRUCTION (ENGLISH, CHINESE)		
4-847-802-00	SCREW		
4-925-079-01	COVER (6), BATTERY		
* 4-933-001-01	CUSHION		
* 4-945-084-01	INDIVIDUAL CARTON		

Note: The components identified by mark Δ or dotted line with mark Δ are critical for safety. Replace only with part number specified.

Ref. No.	Part No.	Description	Remark
----------	----------	-------------	--------

HARDWARE LIST

# 1	7-685-647-79	SCREW +BVTP 3X10 TYPE2 SLIT	
# 2	7-685-234-19	SCREW +KTP 2.6X8 TYPE2 NON-SLIT	
# 3	7-682-567-09	SCREW +B 4X25	
# 4	7-685-646-79	SCREW +BVTP 3X8 TYPE2 IT-3	
# 5	7-685-649-79	SCREW +BVTP 3X12 (S) (AV650G)	
# 5	7-685-152-19	SCREW +P 3X25 TYPE2 SLIT (AV650)	
# 6	7-685-647-79	SCREW +BVTP 3X10 TYPE2 N-S	
# 7	7-621-849-00	SCREW (BV/RING)	
# 8	7-685-648-79	SCREW +BVTP 3X12 TYPE2 IT-3	
# 9	7-682-551-09	SCREW +BVTT 3X14 (S)	
#10	7-682-550-09	SCREW +BVTT 3X12 (S)	
#11	7-684-024-04	N 4, TYPE 2	
#12	7-682-554-09	SCREW +BVTT 3X25 (S)	
#13	7-682-548-04	SCREW +BVTT 3X8 (S)	
#14	7-685-650-79	SCREW +BVTP 3X16 TYPE2 IT-3	
#15	7-685-647-79	SCREW +BVTP 3X10 TYPE2 SLIT	
#16	7-682-547-09	SCREW +BV 3×6 S TIGHT	

TA-AV650/AV650G

SONY[®] SERVICE MANUAL

US Model
TA-AV650

E Model
TA-AV650G

CORRECTION-1

Correct your service manual as shown below.

- The connecting destinations of the tester have been omitted in the AUTO INPUT BALANCE adjustment on page 25 of the service guide. Connect and adjust a tester to both ends of D302 (or D303) as shown in the diagram below.

 : Corrected portions

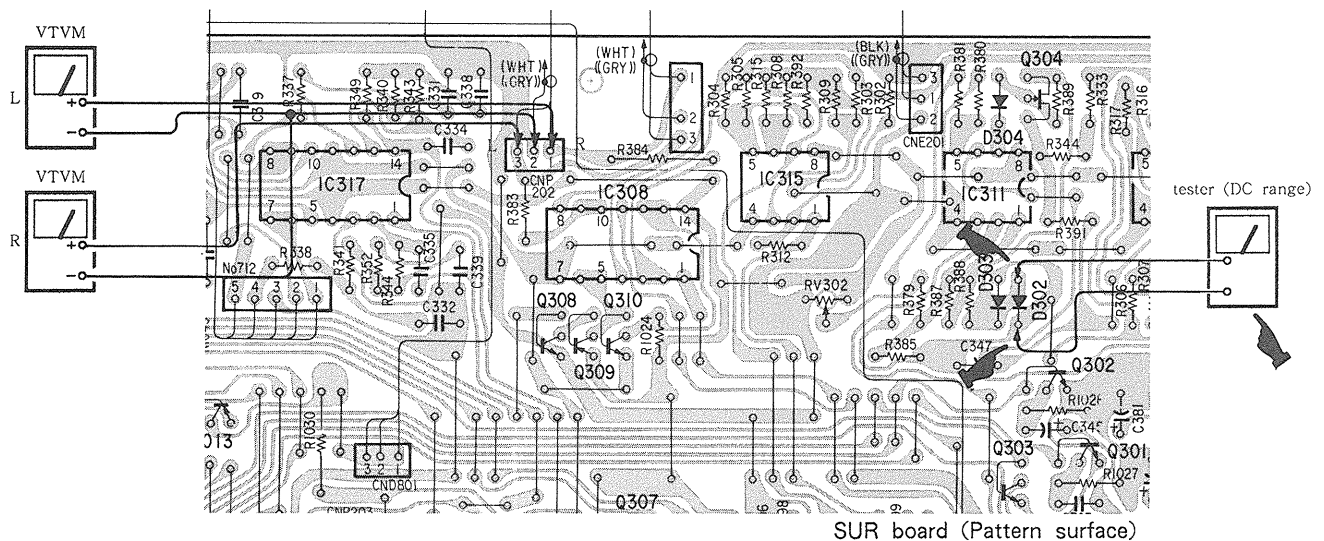

• This is the FL001 internal wiring diagram that was omitted in the service manual.

FL001

